

BID ADVERTISEMENT FOR THE WEEKS OF

September 4, 2024 & September 11, 2024

BID OPENS - THURSDAY OCTOBER 3, 2024

FILE NO. 102-24 Adjustable Valve Boxes & Appurtenances

FOR THE DIVISION OF WATER FOR THE DEPARTMENT OF PUBLIC UTILITIES AS AUTHORIZED BY ORDINANCE 129.25. PASSED BY COUNCIL SEPTEMBER 21, 1992.

There will be a **NON-MANDATORY Pre-Bid Meeting, Thursday, September 12, 2024 at 9:30 am., Via WebEx, to call into the meeting dial 1-415-655-0003, Access Code 2309 474 7246.**

Note: Bid must be delivered to the Office of the Commissioner of Purchases and Supplies, Cleveland City Hall, 601 Lakeside Avenue, Room 128, Cleveland, Ohio 44114 before 12 o'clock noon (Eastern Time).



**CITY OF CLEVELAND,
OHIO**

DEPARTMENT OF FINANCE



DIVISION OF PURCHASES AND SUPPLIES

INVITATION TO BID

**INVITATION TO BID AND FORMAL BID PACKAGE
TABLE OF CONTENTS**

<u>ITEMS</u>	<u>SEQUENCE ORDER NUMBER</u>
Authorizing Ordinance.....	1
Bidder's Checklist.....	2
Instructions to Bidders (Part A).....	3
W-9 Form.....	4
Vendor Information Form.....	5
Bidder's Affidavit.....	6
Bid Bond.....	7
Bid Form.....	8
Bid Schedule of Items (Price Sheets).....	9
General Conditions (Part B).....	10
Specifications/Description of Products and/or Services (Supplemental Sections C, D, etc.).....	11
Nothern Ireland Form.....	12
Prevailing Wage, Davis Beacon or Living Wage (If applicable).....	13
Fannie M. Lewis, Chapter 188 (If applicable).....	14
Office of Equal Opportunitay Notice to Bidders, Chapter 187.....	15
Office of Equal Opportunity Clause.....	16
OEO Participation Form.....	17
OEO Schedules Checklist.....	18
OEO Schedules 1- 4.....	19
Subcontracting Participation or Waiver Form.....	20
OEO Submission Schedule.....	21

CITY OF CLEVELAND
Department of Finance
Division of Purchases and Supplies
City Hall, Room 128
Cleveland, Ohio 44114
216-664-2620

129.25 Purchase of Water System Maintenance Equipment

The Director of Public Utilities is authorized to enter into one or more standard purchase or requirement contracts duly let to the lowest and best bidder after competitive bidding for Water system maintenance equipment deemed by the Director of Public Utilities to be necessary to the operations of the Division of Water, including, but not limited to: meters and meter parts; manhole covers, rings, and manholes; ductile iron pipe and fittings; copper pipe and tubing; parts for pumps, engines and saws; service fittings and pipe couplings; lining cement, mortar cement and sand; valves, valve boxes, and appurtenances; bypass piping, fittings and valves; fire hydrants and fire hydrant parts; pipe repair clamps; and stop cock boxes. Any purchase made pursuant to this section shall be made by the Commissioner of Purchases and Supplies and paid from the annual appropriations made for such purpose.

(Ord. No. 1630-92. Passed 9-21-92, eff. 9-25-92)

City of Cleveland

DEPARTMENT OF FINANCE
JIM HARTLEY
INTERIM CHIEF FINANCE OFFICER



DIVISION OF PURCHASES AND SUPPLIES
TIFFANY JOHNSON
COMMISSIONER

BIDDER'S CHECK LIST

The City of Cleveland requires that each bid submitted must comply with certain legal requirements to be considered a valid and formal bid. The checklist below is provided to assist in avoiding rejection of your bid due to omission of required information or forms.

CHECK WHEN COMPLETED

A. Bid/Schedule of Items

- 1. Is (are) the bid page(s) completed as required **and** signed in the upper right-hand corner?
- 2. Are all prices (whether Unit, or Gross and extensions) clearly and accurately presented?
- 3. Is the delivery time stated? Is the payment discount given?

B. Bid Bond

- 1. Is the bond made out in the names of and signed by both the principal **and** surety?
- 2. Is the bond amount sufficient for the amount of the bid?
- 3. Is there a power of attorney attached to the bond?

C. Bid Check (if submitted in lieu of Bid Bond)

- 1. Is the check in an amount sufficient for the amount of the bid?
- 2. Is the check either properly certified or a cashier's check?
- 3. Is the Check made payable to: THE CITY OF CLEVELAND?

D. Bid Form (not to be confused with the Bid Bond)

- 1. Is all the required information given?
- 2. Is the form signed?

E. Affidavit

- 1. Does the affidavit contain all the information required ON BOTH SIDES?
- 2. Is it properly Signed? Is it properly notarized by a Notary Public?

F. Contract Compliance Certifications for Bid Consideration

- 1. Do you have questions about a contract compliance certification number or a CSB/ minority/female business enterprise certification number, contact the Office of the Director of Equal Opportunity for further information (Phone 216/664-4152).
- 2. Is your contract compliance certification certificate, statement of deemed compliance, or an application for certification included in the bid?
- 3. If you are a Minority/Female/Cleveland Small Business Enterprise and or Local Producer/ Local Sustainable Business, do you include your MBE/FBE/LPE/SUBE certification certificate, or a completed application therein?
- 4. Did you read and complete OEO Schedules 1-4? Did you include signed Schedule 3's from all certified subcontractors?

G. Bid Envelope

- 1. Is the envelope identified with the correct title of the bid and the due date?
- 2. Is the envelope securely sealed?

H. Performance Bond

- 1. Will you be able to furnish the required Performance Bond referred to in paragraph A-8 of INSTRUCTIONS TO BIDDERS, and/or in paragraph B-8 of General Conditions?
- 2. Notice: A certified or cashier's check is **not acceptable in lieu of a Performance Bond!**

I. **Federal Tax ID Form**

- ___ 1. Is all the required information given?
- ___ 2. Is the form signed?

J. **Northern Ireland Fair Employment Practices Disclosure**

- ___ 1. Is all the required information given?
- ___ 2. Is the form signed?

K. **Project Plan**

- ___ 1. Is all the required information given?

L. **Contractor Qualifications**

- ___ 1. Is all the required information given if requested?

K. **Please Note:**

- ___ 1. Because of the large variety of commodities, services and improvements required by the City, additional information is often requested in a format not listed above. In such a case, **please review your bid carefully to verify that you have accurately and completely supplied all such data.** Should you have any questions, please call the Division of Purchases and Supplies (216/664-2620) for clarifications.
- ___ 2. All plans and specifications **must** be returned with the bid.

INSTRUCTIONS TO BIDDERS

A-1 INVITATION TO BID

Sealed bids endorsed as designated in the "Title of Bid" section of the bid sheet(s) will be received at the Office of the Commissioner of Purchases and Supplies, Room 128, Cleveland City Hall, Cleveland, Ohio 44114, until 12:00 o'clock noon, official time, on the date indicated in the "Bid Opening" section of Page 1 of the bid page(s) and thereafter will be publicly opened and read in Room 128.

A-2 FORM OF BID (BID FORM)

- a. Every bid must be made upon the blank form of bid attached hereto.
- b. Each bid must be clearly signed with the full name and address of every person, firm or corporation interested in such bid, followed by the date of such signing, in the space provided at the bottom of the bid form. If more than one person, firm or corporation has an interest in such bid, then the full name and address of each person, firm or corporation must be clearly signed on said bid. If the bidder is a partnership, the firm name and address, as well as the name and address of each individual partner must be given. If the bidder is a corporation, the name of the corporation, the name and title of the officer duly authorize to sign for the corporation, the business address of such officer and the name of the state in which the corporation is incorporated must be given.
- c. The bidder shall insert the amount of the bid bond, certified check or cashier's check in the space provided in the bid form.
- d. The bidder agrees to be bound by his bid from the time the bid is submitted until the earlier of the date stipulated by such bidder or the fourth regular meeting of the Board of Control after the bid submission date unless such time is extended by agreement between the bidder and the Board.

A-3 BIDDERS AFFIDAVIT

Each bidder shall submit with its bid an affidavit stating that neither it nor its agents, nor any other party for it has paid or agreed to pay, directly or indirectly, any person, firm or corporation any money or valuable consideration for assistance in procuring or attempting to procure the contract herein referred to, and further stating that no such money or reward will be hereafter paid. This affidavit must be on the form which is hereto attached.

A-4 BID BOND: CERTIFIED OR CASHIER'S CHECK

Each bid shall be accompanied by a bid bond signed by a surety company authorized to do business in Ohio, or by a cashier's check or certified check on a solvent bank, which bond or check shall be in the sum of five percent (5%) of the amount of the bid, except that with bids for purchase contracts not in excess of Fifty Thousand Dollars (\$50,000). Said bond or check shall be given as security that if the bid is accepted a contract will be entered into and the performance of it properly secured.

A-5 DISPOSITION OF BID BOND, CERTIFIED OR CASHIER'S CHECK

- a. When the bid is accepted, the bid bond, certified or cashier's check will be returned after the contract has been signed and the performance bond, if required, has been submitted to, and approved by, the City.
- b. If the successful bidder fails to enter into a contract, the bid bond, certified or cashier's check shall be forfeited and the principal amount of the bid bond shall be paid to the City, or the check shall be surrendered to the City as the agreed amount of liquidated damages.
- c. The bid bond, certified or cashier's check of the next lowest and best bidder will be retained until the lowest and best bidder has signed and secured the performance of its contract. If such lowest and best bidder fails to do so, the security of the next lowest and best bidder shall continue to be retained until it properly secures the contract awarded it. If such next lowest and best bidder defaults, the principal amount of its bid bond, or check shall also be forfeited to the City as liquidated damages.
- d. When a bid is rejected, the bid bond or check will be released or returned, respectively, to the bidder.

A-6 EXPLANATIONS WRITTEN OR ORAL

Any bidder finding a discrepancy or omission in the specifications or having any doubt as to their meaning, shall immediately notify the Commissioner of Purchases and Supplies, in writing. The Commissioner will respond by sending written notices or instructions to all bidders. The City will not be responsible for any oral instructions.

A-7 PRICE BIDS AND DISCOUNTS

- a. **Unit Prices**
In the Schedule of Items the bidder must give the unit price stated in figures of every item bid, in the space so provided.
- b. **Trade Discounts**
When the bidder offers a trade discount, the amount of such discount shall be stated on the Schedule of Items bid.
- c. **Catalog Pricing**
Where the bidder submits its quotation by filing its catalog price list and discount, such documents shall be part of the bid and must be separately signed by the same person and in the same manner as on the bid form.

A-8 BIDDER'S DESCRIPTION OF ITEMS

- a. Each bidder shall, in its bid, describe completely the goods or services it proposes to furnish in response to and under the terms of the bid.
- b. The Commissioner of Purchases and Supplies may require a bidder to furnish additional information and/or specifications concerning items to be purchased under the terms of the bid.

A-9 MANUFACTURER'S NAME

- a. The use of a manufacturer's or a trade name in the specifications is solely for the purpose of designating a standard of quality and type and for no other purpose.
- b. Every bidder shall state in its Schedule of Items bid the manufacturer's and the trade name, if any, of each item they propose to furnish.

A-10 SAMPLES

If the commissioner of Purchases and Supplies requests, a bidder shall provide samples of the items it proposes to furnish if awarded a contract pursuant to its bid.

A-11 TIME OF DELIVERY

Bidder must state in its bid the time, in calendar days, within which it will deliver the item(s) bid unless stated differently in the specifications.

A-12 PAYMENT DISCOUNT WHEN USED TO DETERMINE LOWEST AND BEST BID

- a. In determining the lowest and best bid, the City will consider all bids on a basis of the net price to be paid after deduction of the discount specified; except that if the terms of payment specified by the bidder require payment in less than thirty (30) days from the date of the invoice, the discount offered will not be deducted from the price stated in the bid to determine the lowest and best bidder, and the bid will be considered only on the basis of the unit price actually named in the bid. But if, notwithstanding the provisions of this paragraph such bid is determined to be the lowest and best bid, the City reserves the right to accept the terms named in the bid if such terms are to the advantage of the City as a basis for payment of invoices only, but not in any case as a basis for determining the lowest and best bidder.
- b. The City will take a discount of two percent (2%) on payments made within thirty (30) days from receipt of articles, commodities, materials, supplies, equipment or services, unless the bidder indicates otherwise on the space provided on the Schedule of Items bid.

PARAGRAPHS A-13 THROUGH A-15 APPLY ONLY IF THE "REQUIREMENT CONTRACT" BLOCK IS CHECKED ON PAGE 1 OF THE SCHEDULE OF ITEMS AND ON THE BID FORM.

A-13 REQUIREMENT CONTRACT DEFINED

- a. A requirement contract is a contract under which the contractor has a duty to provide the City's requirements during the contract term for all articles, commodities, supplies, materials, equipment and/or services set forth in the bid and required by the City's authorized users of the items approved for contract.
- b. A contract awarded under this bid will be termed a requirement contract.

A-14 PURCHASES UNDER A REQUIREMENT CONTRACT

- a. Under a requirement contract, a contractor shall supply all the City's requirements during the term for the articles, commodities, supplies, materials, services or equipment set forth in the *Invitation to Bid*. See GENERAL CONDITIONS, Section B-24, **Duration of Contract**.
- b. If the *Schedule of Items* in the *Invitation to Bid* is marked "requirement contract," then all quantities stated in the *Schedule of Items* are the City's good-faith estimates only. The City shall place each order under the

contract, whether singly or cumulatively more or less than the estimated quantities set forth in the *Schedule of Items*, by a Delivery Order against the contract and separately certified.

A-15 LIMITATION OF PERIOD OF CONTRACT

If the proposed duration of the contract would deprive the City of the best available market price, the bidder may offer an alternate bid as to duration of the contract, setting forth in the bid the longest period of time it can furnish and deliver the proportionate amount of items at the firm price set forth in the bid. No other provision of the Invitation to Bid shall be subject to an alternate bid unless specifically requested.

A-16 BID DISCOUNTS - APPLICABLE TO BIDS FOR GOODS AND SERVICES PURCHASE CONTRACTS AND PUBLIC IMPROVEMENT CONTRACTS IN EXCESS OF FIFTY THOUSAND DOLLARS (\$50,000).

a. Bid Discounts under Sections 187.03 and 187.05. If the bid of any prime contractor that is a CSB, MBE, FBE or a CSB, MBE or FBE joint venture is no more than five percent (5%) higher than the lowest actual bid for a contract that is not from a CSB, MBE, FBE or a CSB, MBE or FBE joint venture, the contracting department shall apply a Bid Discount of five percent (5%) to the CSB, MBE, FBE or CSB, MBE or FBE joint venture bid for the purpose of establishing a Comparison Bid. The City of Cleveland shall use the following ranking in determining who receives the preference:

1. Where the disparity study has determined that a disparity exists, the bid discount shall go to the bidders who are certified by the City as members of the specific MBE/FBE group for which the proven disparity exists. No other bidders shall receive any preference under Sections 187.03 and 187.05 at the prime contractor level.
2. Where no disparity has been proven, or when no bids are received from groups for which a proven disparity exists, the bid discount shall go to certified CSB bidders certified by the City as located within the city limits of Cleveland. No other bidders shall receive any preference under Sections 187.03 and 187.05 at the prime contractor level.
3. Where no disparity has been proven, or when no bids are received from groups for which a proven disparity exists, and no bids were received from certified CSB firms certified by the City as located within the city limits of Cleveland, the bid discount shall go to Certified CSB bidders certified by the City as located within Cuyahoga County. No other bidders shall receive any preference under Sections 187.03 and 187.05 at the prime contractor level.
4. In addition to any bid discounts at the prime contractor level, all prime contractors shall receive a bid discount of 5% of the total dollar amount of all CSB, MBE and/or FBE certified by the City that the prime contractor properly documents as subcontractors in their bid, for the purpose of establishing a Comparison Bid.
5. The total Bid Discount awarded to any bidder on a bid pursuant to Sections 187.03 and 187.05 shall not exceed \$50,000.00.

b. Bid Discounts under Section 187A.02(a): Application of Bid Discount - A Contracting Department shall apply a Bid Discount of two percent (2%) to a bid received from a Local Producer (LPE); two percent (2%) to a bid received from a Local Food-Producer (LPE); and two percent (2%) to a bid received from a Local Sustainable Business (SUBE); provided that the maximum total Bid Discount applied under Section 187A.02 (a) shall not exceed four percent (4%). Bid Discounts applied under Section 187A.02 (a) shall be in addition to any Bid Discount applied under Sections 187.03 and 187.05. The maximum amount of any Bid Discounts applied under this Section 187A.02 (a) shall not exceed \$50,000.

c. Maximum Cumulative Amount of All Bid Discounts:

The maximum cumulative amount of all Bid Discounts that may be applied to the bid under Sections 187.03, 187.05, and 187A.02 shall not exceed \$75,000.00, or nine percent (9%), whichever is lower.

d. Comparison Bid to Determine Lowest and Best Bidder:

The City shall determine the Comparison Bid by totaling all applicable Bid Discounts under Sections 187.03, 187.05, and 187A.02. The City shall use the Comparison Bid in determining the lowest and best or lowest responsible bidder for the purpose of awarding the contract. If more than one CSB, MBE, FBE, LPE, SUBE or CSB, MBE, FBE LPE, SUBE joint venture prime contractor in the respective category submits a bid that is no more than five percent (5%) higher than the lowest actual bid that is not from a CSB, MBE, FBE, LPE, SUBE or from a CSB, MBE, FBE, LPE, SUBE joint venture, the contracting department shall recommend the CSB, MBE, FBE, LPE, SUBE, or CSB, MBE, FBE, LPE, SUBE joint venture submitting the lowest bid, after the inclusion of all applicable prime and subcontractor discounts, as the lowest and best or lowest responsible bidder.

The City shall use the Comparison Bid amount determined by applying the bid discounts described in Articles A-16A. and A-16B. above for evaluation purposes only; the City shall use the actual bid amount for the purposes of bid approval and contract award.

e. City of Cleveland Certification required: For the purpose of determining a bidder's eligibility for bid discounts, the City shall only consider bidders with valid certificates issued by the City of Cleveland's Office of Equal Opportunity. The certifications must be active on the date and time of the deadline for bid submission. Expired certification holders and pending certifications cannot be considered for calculation of bid discounts. Certifications from other public or private entities cannot be considered.

A-17 Good Faith Participation - APPLICABLE TO BIDS FOR GOODS AND SERVICES PURCHASE CONTRACTS AND PUBLIC IMPROVEMENT CONTRACTS IN EXCESS OF FIFTY THOUSAND DOLLARS (\$50,000).

Bidders are required to actively participate and demonstrate good faith in attempting to meet all OEO goals for this procurement. A good faith effort to meet certified CSB, MBE, and/or FBE subcontractor participation goals as established in this contract is of the essence of the contract.

Good faith participation shall include:

1. Active cooperation in making and documenting a serious effort to gain and maintain participation from certified businesses at or above the specific goals set for this procurement;
2. Achieving or exceeding the CSB/MBE/FBE goals set for this particular procurement and/or documenting the practical steps taken by the bidder in attempting to comply;
3. Active attendance and participation in all prebid meetings, Notice to Proceed meetings, and progress meetings during the contract;
4. Active compliance and cooperation with Project Monitors from OEO and/or the Department; and,
5. Timely and accurate submittals of all required forms, including, but not limited to, electronic monitoring forms, employment reports and certified payrolls if applicable.

The final determination of good faith effort shall be made by the Office of Equal Opportunity based upon each bidder's actions as documented in the required forms and as verified by OEO follow up.

A-18 Cleveland Area Business Code Notice to Bidders & Schedules - APPLICABLE TO BIDS FOR GOODS AND SERVICES PURCHASE CONTRACTS AND PUBLIC IMPROVEMENT CONTRACTS IN EXCESS OF FIFTY THOUSAND DOLLARS (\$50,000).

Sections 187 and 187A of the Codified Ordinances of the City of Cleveland Ohio, the Cleveland Area Business Code, in its entirety, whether reproduced in whole or in part within these documents, as well as the Cleveland Area Business Code Notice to Bidders & Schedules included in this bid document, shall become part of any contract awarded pursuant to this Invitation to Bid. Compliance with Section 187 and 187A is of the essence of the contract.

A-19 SUBCONTRACTING:

a. Any and all proposed subcontractors, whether City certified or not, must be divulged and listed in the sealed bid. Include all proposed subcontractors on OEO Schedule 2. A Schedule 3 is also required for each proposed subcontractor that is CSB, MBE, FBE, LPE, or SUBE certified. However, a Schedule 3 is not required for proposed subcontractors who are not City-certified as a CSB, MBE, FBE, LPE, or SUBE.

b. If OEO Schedule 2 is not included in the bid documents, you must submit a proposed subcontractor list on a separate, signed sheet of paper, listing the name, address, type of work or materials, and total subcontractor amount for each and every subcontractor that you propose to use on the contract.

c. All proposed subcontractors listed in your bid must receive written Board of Control approval in advance. The subcontractors you propose in your sealed bid will be considered the subcontractors that you will use in the contract if awarded to you. See Article B-11 regarding the City's Sub-contractor Addition and Substitution Policy and Procedure. The City also reserves the right to approve an award, but not approve a proposed subcontractor.

d. The City maintains a list of Vendors Ineligible to Contract or Subcontract with the City at the City of Cleveland website: <http://www.city.cleveland.oh.us>. It is each bidder's responsibility to propose only eligible contractors. The City cannot approve a subcontractor whose name appears in this listing.

Request for Taxpayer Identification Number and Certification

Give Form to the
 requester. Do not
 send to the IRS.

▶ Go to www.irs.gov/FormW9 for instructions and the latest information.

Print or type. See Specific instructions on page 3.	1 Name (as shown on your income tax return). Name is required on this line; do not leave this line blank.	
	2 Business name/disregarded entity name, if different from above	
	3 Check appropriate box for federal tax classification of the person whose name is entered on line 1. Check only one of the following seven boxes.	4 Exemptions (codes apply only to certain entities, not individuals; see instructions on page 3):
	<input type="checkbox"/> Individual/sole proprietor or single-member LLC <input type="checkbox"/> Limited liability company. Enter the tax classification (C=C corporation, S=S corporation, P=Partnership) ▶ _____ <small>Note: Check the appropriate box in the line above for the tax classification of the single-member owner. Do not check LLC if the LLC is classified as a single-member LLC that is disregarded from the owner unless the owner of the LLC is another LLC that is not disregarded from the owner for U.S. federal tax purposes. Otherwise, a single-member LLC that is disregarded from the owner should check the appropriate box for the tax classification of its owner.</small> <input type="checkbox"/> Other (see instructions) ▶ _____	Exempt payee code (if any) _____ Exemption from FATCA reporting code (if any) _____ <small>(Applies to accounts maintained outside the U.S.)</small>
	5 Address (number, street, and apt. or suite no.) See instructions.	Requester's name and address (optional)
	6 City, state, and ZIP code	
	7 List account number(s) here (optional)	

Part I Taxpayer Identification Number (TIN)											
Enter your TIN in the appropriate box. The TIN provided must match the name given on line 1 to avoid backup withholding. For individuals, this is generally your social security number (SSN). However, for a resident alien, sole proprietor, or disregarded entity, see the instructions for Part I, later. For other entities, it is your employer identification number (EIN). If you do not have a number, see <i>How to get a TIN</i> , later. Note: If the account is in more than one name, see the instructions for line 1. Also see <i>What Name and Number To Give the Requester</i> for guidelines on whose number to enter.	<table border="1" style="width: 100%; border-collapse: collapse;"> <tr> <td colspan="2" style="text-align: center; padding: 2px;">Social security number</td> </tr> <tr> <td style="width: 40px; text-align: center;">[] [] [] [] - [] [] - [] [] [] []</td> <td style="width: 40px;"></td> </tr> <tr> <td colspan="2" style="text-align: center; padding: 2px;">or</td> </tr> <tr> <td colspan="2" style="text-align: center; padding: 2px;">Employer identification number</td> </tr> <tr> <td style="width: 40px; text-align: center;">[] [] [] [] [] [] [] [] [] [] - [] [] [] [] [] [] [] [] [] []</td> <td style="width: 40px;"></td> </tr> </table>	Social security number		[] [] [] [] - [] [] - [] [] [] []		or		Employer identification number		[] [] [] [] [] [] [] [] [] [] - [] [] [] [] [] [] [] [] [] []	
Social security number											
[] [] [] [] - [] [] - [] [] [] []											
or											
Employer identification number											
[] [] [] [] [] [] [] [] [] [] - [] [] [] [] [] [] [] [] [] []											

Part II Certification	
Under penalties of perjury, I certify that:	
1. The number shown on this form is my correct taxpayer identification number (or I am waiting for a number to be issued to me); and 2. I am not subject to backup withholding because: (a) I am exempt from backup withholding, or (b) I have not been notified by the Internal Revenue Service (IRS) that I am subject to backup withholding as a result of a failure to report all interest or dividends, or (c) the IRS has notified me that I am no longer subject to backup withholding; and 3. I am a U.S. citizen or other U.S. person (defined below); and 4. The FATCA code(s) entered on this form (if any) indicating that I am exempt from FATCA reporting is correct.	
Certification instructions. You must cross out item 2 above if you have been notified by the IRS that you are currently subject to backup withholding because you have failed to report all interest and dividends on your tax return. For real estate transactions, item 2 does not apply. For mortgage interest paid, acquisition or abandonment of secured property, cancellation of debt, contributions to an individual retirement arrangement (IRA), and generally, payments other than interest and dividends, you are not required to sign the certification, but you must provide your correct TIN. See the instructions for Part II, later.	
Sign Here	Signature of U.S. person ▶ _____
	Date ▶ _____

General Instructions

Section references are to the Internal Revenue Code unless otherwise noted.

Future developments. For the latest information about developments related to Form W-9 and its instructions, such as legislation enacted after they were published, go to www.irs.gov/FormW9.

Purpose of Form

An individual or entity (Form W-9 requester) who is required to file an information return with the IRS must obtain your correct taxpayer identification number (TIN) which may be your social security number (SSN), individual taxpayer identification number (ITIN), adoption taxpayer identification number (ATIN), or employer identification number (EIN), to report on an information return the amount paid to you, or other amount reportable on an information return. Examples of information returns include, but are not limited to, the following:

- Form 1099-DIV (dividends, including those from stocks or mutual funds)
- Form 1099-MISC (various types of income, prizes, awards, or gross proceeds)
- Form 1099-B (stock or mutual fund sales and certain other transactions by brokers)
- Form 1099-S (proceeds from real estate transactions)
- Form 1099-K (merchant card and third party network transactions)
- Form 1098 (home mortgage interest), 1098-E (student loan interest), 1098-T (tuition)
- Form 1099-C (canceled debt)
- Form 1099-A (acquisition or abandonment of secured property)

Use Form W-9 only if you are a U.S. person (including a resident alien), to provide your correct TIN.

If you do not return Form W-9 to the requester with a TIN, you might be subject to backup withholding. See What is backup withholding, later.

By signing the filled-out form, you:

1. Certify that the TIN you are giving is correct (or you are waiting for a number to be issued),
2. Certify that you are not subject to backup withholding, or
3. Claim exemption from backup withholding if you are a U.S. exempt payee. If applicable, you are also certifying that as a U.S. person, your allocable share of any partnership income from a U.S. trade or business is not subject to the withholding tax on foreign partners' share of effectively connected income, and
4. Certify that FATCA code(s) entered on this form (if any) indicating that you are exempt from the FATCA reporting, is correct. See *What is FATCA reporting*, later, for further information.

Note: If you are a U.S. person and a requester gives you a form other than Form W-9 to request your TIN, you must use the requester's form if it is substantially similar to this Form W-9.

Definition of a U.S. person. For federal tax purposes, you are considered a U.S. person if you are:

- An individual who is a U.S. citizen or U.S. resident alien;
- A partnership, corporation, company, or association created or organized in the United States or under the laws of the United States;
- An estate (other than a foreign estate); or
- A domestic trust (as defined in Regulations section 301.7701-7).

Special rules for partnerships. Partnerships that conduct a trade or business in the United States are generally required to pay a withholding tax under section 1446 on any foreign partners' share of effectively connected taxable income from such business. Further, in certain cases where a Form W-9 has not been received, the rules under section 1446 require a partnership to presume that a partner is a foreign person, and pay the section 1446 withholding tax. Therefore, if you are a U.S. person that is a partner in a partnership conducting a trade or business in the United States, provide Form W-9 to the partnership to establish your U.S. status and avoid section 1446 withholding on your share of partnership income.

In the cases below, the following person must give Form W-9 to the partnership for purposes of establishing its U.S. status and avoiding withholding on its allocable share of net income from the partnership conducting a trade or business in the United States.

- In the case of a disregarded entity with a U.S. owner, the U.S. owner of the disregarded entity and not the entity;
- In the case of a grantor trust with a U.S. grantor or other U.S. owner, generally, the U.S. grantor or other U.S. owner of the grantor trust and not the trust; and
- In the case of a U.S. trust (other than a grantor trust), the U.S. trust (other than a grantor trust) and not the beneficiaries of the trust.

Foreign person. If you are a foreign person or the U.S. branch of a foreign bank that has elected to be treated as a U.S. person, do not use Form W-9. Instead, use the appropriate Form W-8 or Form 8233 (see Pub. 515, *Withholding of Tax on Nonresident Aliens and Foreign Entities*).

Nonresident alien who becomes a resident alien. Generally, only a nonresident alien individual may use the terms of a tax treaty to reduce or eliminate U.S. tax on certain types of income. However, most tax treaties contain a provision known as a "saving clause." Exceptions specified in the saving clause may permit an exemption from tax to continue for certain types of income even after the payee has otherwise become a U.S. resident alien for tax purposes.

If you are a U.S. resident alien who is relying on an exception contained in the saving clause of a tax treaty to claim an exemption from U.S. tax on certain types of income, you must attach a statement to Form W-9 that specifies the following five items:

1. The treaty country. Generally, this must be the same treaty under which you claimed exemption from tax as a nonresident alien.
2. The treaty article addressing the income.
3. The article number (or location) in the tax treaty that contains the saving clause and its exceptions.
4. The type and amount of income that qualifies for the exemption from tax.
5. Sufficient facts to justify the exemption from tax under the terms of the treaty article.

Example. Article 20 of the U.S.-China income tax treaty allows an exemption from tax for scholarship income received by a Chinese student temporarily present in the United States. Under U.S. law, this student will become a resident alien for tax purposes if his or her stay in the United States exceeds 5 calendar years. However, paragraph 2 of the first Protocol to the U.S.-China treaty (dated April 30, 1984) allows the provisions of Article 20 to continue to apply even after the Chinese student becomes a resident alien of the United States. A Chinese student who qualifies for this exception (under paragraph 2 of the first protocol) and is relying on this exception to claim an exemption from tax on his or her scholarship or fellowship income would attach to Form W-9 a statement that includes the information described above to support that exemption.

If you are a nonresident alien or a foreign entity, give the requester the appropriate completed Form W-8 or Form 8233.

Backup Withholding

What is backup withholding? Persons making certain payments to you must under certain conditions withhold and pay to the IRS 24% of such payments. This is called "backup withholding." Payments that may be subject to backup withholding include interest, tax-exempt interest, dividends, broker and barter exchange transactions, rents, royalties, nonemployee pay, payments made in settlement of payment card and third party network transactions, and certain payments from fishing boat operators. Real estate transactions are not subject to backup withholding.

You will not be subject to backup withholding on payments you receive if you give the requester your correct TIN, make the proper certifications, and report all your taxable interest and dividends on your tax return.

Payments you receive will be subject to backup withholding if:

1. You do not furnish your TIN to the requester,
2. You do not certify your TIN when required (see the instructions for Part II for details),
3. The IRS tells the requester that you furnished an incorrect TIN,
4. The IRS tells you that you are subject to backup withholding because you did not report all your interest and dividends on your tax return (for reportable interest and dividends only), or
5. You do not certify to the requester that you are not subject to backup withholding under 4 above (for reportable interest and dividend accounts opened after 1983 only).

Certain payees and payments are exempt from backup withholding. See *Exempt payee code*, later, and the separate instructions for the Requester of Form W-9 for more information.

Also see *Special rules for partnerships*, earlier.

What is FATCA Reporting?

The Foreign Account Tax Compliance Act (FATCA) requires a participating foreign financial institution to report all United States account holders that are specified United States persons. Certain payees are exempt from FATCA reporting. See *Exemption from FATCA reporting code*, later, and the instructions for the Requester of Form W-9 for more information.

Updating Your Information

You must provide updated information to any person to whom you claimed to be an exempt payee if you are no longer an exempt payee and anticipate receiving reportable payments in the future from this person. For example, you may need to provide updated information if you are a C corporation that elects to be an S corporation, or if you no longer are tax exempt. In addition, you must furnish a new Form W-9 if the name or TIN changes for the account; for example, if the grantor of a grantor trust dies.

Penalties

Failure to furnish TIN. If you fail to furnish your correct TIN to a requester, you are subject to a penalty of \$50 for each such failure unless your failure is due to reasonable cause and not to willful neglect. **Civil penalty for false information with respect to withholding.** If you make a false statement with no reasonable basis that results in no backup withholding, you are subject to a \$500 penalty.

Criminal penalty for falsifying information. Willfully falsifying certifications or affirmations may subject you to criminal penalties including fines and/or imprisonment.

Misuse of TINs. If the requester discloses or uses TINs in violation of federal law, the requester may be subject to civil and criminal penalties.

Specific Instructions

Line 1

You must enter one of the following on this line; do not leave this line blank. The name should match the name on your tax return.

If this Form W-9 is for a joint account (other than an account maintained by a foreign financial institution (FFI)), list first, and then circle, the name of the person or entity whose number you entered in Part I of Form W-9. If you are providing Form W-9 to an FFI to document a joint account, each holder of the account that is a U.S. person must provide a Form W-9.

a. Individual. Generally, enter the name shown on your tax return. If you have changed your last name without informing the Social Security Administration (SSA) of the name change, enter your first name, the last name as shown on your social security card, and your new last name.

Note: ITIN applicant: Enter your individual name as it was entered on your Form W-7 application, line 1a. This should also be the same as the name you entered on the Form 1040/1040A/1040EZ you filed with your application.

b. Sole proprietor or single-member LLC. Enter your individual name as shown on your 1040/1040A/1040EZ on line 1. You may enter your business, trade, or "doing business as" (DBA) name on line 2.

c. Partnership, LLC that is not a single-member LLC, C corporation, or S corporation. Enter the entity's name as shown on the entity's tax return on line 1 and any business, trade, or DBA name on line 2.

d. Other entities. Enter your name as shown on required U.S. federal tax documents on line 1. This name should match the name shown on the charter or other legal document creating the entity. You may enter any business, trade, or DBA name on line 2.

e. Disregarded entity. For U.S. federal tax purposes, an entity that is disregarded as an entity separate from its owner is treated as a "disregarded entity." See Regulations section 301.7701-2(c)(2)(ii). Enter the owner's name on line 1. The name of the entity entered on line 1 should never be a disregarded entity. The name on line 1 should be the name shown on the income tax return on which the income should be reported. For example, if a foreign LLC that is treated as a disregarded entity for U.S. federal tax purposes has a single owner that is a U.S. person, the U.S. owner's name is required to be provided on line 1. If the direct owner of the entity is also a disregarded entity, enter the first owner that is not disregarded for federal tax purposes. Enter the disregarded entity's name on line 2, "Business name/disregarded entity name." If the owner of the disregarded entity is a foreign person, the owner must complete an appropriate Form W-8 instead of a Form W-9. This is the case even if the foreign person has a U.S. TIN.

Line 2

If you have a business name, trade name, DBA name, or disregarded entity name, you may enter it on line 2.

Line 3

Check the appropriate box on line 3 for the U.S. federal tax classification of the person whose name is entered on line 1. Check only one box on line 3.

IF the entity/person on line 1 is a(n) . . .	THEN check the box for . . .
• Corporation	Corporation
• Individual • Sole proprietorship, or • Single-member limited liability company (LLC) owned by an individual and disregarded for U.S. federal tax purposes.	Individual/sole proprietor or single-member LLC
• LLC treated as a partnership for U.S. federal tax purposes, • LLC that has filed Form 8832 or 2553 (to be taxed as a corporation), or • LLC that is disregarded as an entity separate from its owner but the owner is another LLC that is not disregarded for U.S. federal tax purposes.	Limited liability company and enter the appropriate tax classification. (P= Partnership; C= C corporation; or S= S corporation)
• Partnership	Partnership
• Trust/estate	Trust/estate

Line 4, Exemptions

If you are exempt from backup withholding and/or FATCA reporting, enter in the appropriate space on line 4 any code(s) that may apply to you.

Exempt payee code.

- Generally, individuals (including sole proprietors) are not exempt from backup withholding.
- Except as provided below, corporations are exempt from backup withholding for certain payments, including interest and dividends.
- Corporations are not exempt from backup withholding for payments made in settlement of payment card or third party network transactions.
- Corporations are not exempt from backup withholding with respect to attorneys' fees or gross proceeds paid to attorneys, and corporations that provide medical or health care services are not exempt with respect to payments reportable on Form 1099-MISC.

The following codes identify payees that are exempt from backup withholding. Enter the appropriate code in the space in line 4.

- 1—An organization exempt from tax under section 501(c), any IRA, or a custodial account under section 403(b)(7) if the account satisfies the requirements of section 401(f)(2)
- 2—The United States or any of its agencies or instrumentalities
- 3—A state, the District of Columbia, a U.S. commonwealth or possession, or any of their political subdivisions or instrumentalities
- 4—A foreign government or any of its political subdivisions, agencies, or instrumentalities
- 5—A corporation
- 6—A dealer in securities or commodities required to register in the United States, the District of Columbia, or a U.S. commonwealth or possession
- 7—A futures commission merchant registered with the Commodity Futures Trading Commission
- 8—A real estate investment trust
- 9—An entity registered at all times during the tax year under the Investment Company Act of 1940
- 10—A common trust fund operated by a bank under section 584(a)
- 11—A financial institution
- 12—A middleman known in the investment community as a nominee or custodian
- 13—A trust exempt from tax under section 654 or described in section 4947

The following chart shows types of payments that may be exempt from backup withholding. The chart applies to the exempt payees listed above, 1 through 13.

IF the payment is for . . .	THEN the payment is exempt for . . .
Interest and dividend payments	All exempt payees except for 7
Broker transactions	Exempt payees 1 through 4 and 6 through 11 and all C corporations. S corporations must not enter an exempt payee code because they are exempt only for sales of noncovered securities acquired prior to 2012.
Barter exchange transactions and patronage dividends	Exempt payees 1 through 4
Payments over \$600 required to be reported and direct sales over \$5,000 ¹	Generally, exempt payees 1 through 5 ²
Payments made in settlement of payment card or third party network transactions	Exempt payees 1 through 4

¹ See Form 1099-MISC, Miscellaneous Income, and its instructions.

² However, the following payments made to a corporation and reportable on Form 1099-MISC are not exempt from backup withholding: medical and health care payments, attorneys' fees, gross proceeds paid to an attorney reportable under section 6045(f), and payments for services paid by a federal executive agency.

Exemption from FATCA reporting code. The following codes identify payees that are exempt from reporting under FATCA. These codes apply to persons submitting this form for accounts maintained outside of the United States by certain foreign financial institutions. Therefore, if you are only submitting this form for an account you hold in the United States, you may leave this field blank. Consult with the person requesting this form if you are uncertain if the financial institution is subject to these requirements. A requester may indicate that a code is not required by providing you with a Form W-9 with "Not Applicable" (or any similar indication) written or printed on the line for a FATCA exemption code.

- A—An organization exempt from tax under section 501(a) or any individual retirement plan as defined in section 7701(a)(37)
- B—The United States or any of its agencies or instrumentalities
- C—A state, the District of Columbia, a U.S. commonwealth or possession, or any of their political subdivisions or instrumentalities
- D—A corporation the stock of which is regularly traded on one or more established securities markets, as described in Regulations section 1.1472-1(c)(1)(i)
- E—A corporation that is a member of the same expanded affiliated group as a corporation described in Regulations section 1.1472-1(c)(1)(i)
- F—A dealer in securities, commodities, or derivative financial instruments (including notional principal contracts, futures, forwards, and options) that is registered as such under the laws of the United States or any state
- G—A real estate investment trust
- H—A regulated investment company as defined in section 851 or an entity registered at all times during the tax year under the Investment Company Act of 1940
- I—A common trust fund as defined in section 584(b)
- J—A bank as defined in section 581
- K—A broker
- L—A trust exempt from tax under section 664 or described in section 4947(a)(1)

M—A tax exempt trust under a section 403(b) plan or section 457(g) plan

Note: You may wish to consult with the financial institution requesting this form to determine whether the FATCA code and/or exempt payee code should be completed.

Line 5

Enter your address (number, street, and apartment or suite number). This is where the requester of this Form W-9 will mail your information returns. If this address differs from the one the requester already has on file, write NEW at the top. If a new address is provided, there is still a chance the old address will be used until the payor changes your address in their records.

Line 6

Enter your city, state, and ZIP code.

Part I. Taxpayer Identification Number (TIN)

Enter your TIN in the appropriate box. If you are a resident alien and you do not have and are not eligible to get an SSN, your TIN is your IRS individual taxpayer identification number (ITIN). Enter it in the social security number box. If you do not have an ITIN, see *How to get a TIN* below.

If you are a sole proprietor and you have an EIN, you may enter either your SSN or EIN.

If you are a single-member LLC that is disregarded as an entity separate from its owner, enter the owner's SSN (or EIN, if the owner has one). Do not enter the disregarded entity's EIN. If the LLC is classified as a corporation or partnership, enter the entity's EIN.

Note: See *What Name and Number To Give the Requester*, later, for further clarification of name and TIN combinations.

How to get a TIN. If you do not have a TIN, apply for one immediately. To apply for an SSN, get Form SS-5, Application for a Social Security Card, from your local SSA office or get this form online at www.SSA.gov. You may also get this form by calling 1-800-772-1213. Use Form W-7, Application for IRS Individual Taxpayer Identification Number, to apply for an ITIN, or Form SS-4, Application for Employer Identification Number, to apply for an EIN. You can apply for an EIN online by accessing the IRS website at www.irs.gov/Businesses and clicking on Employer Identification Number (EIN) under Starting a Business. Go to www.irs.gov/Forms to view, download, or print Form W-7 and/or Form SS-4. Or, you can go to www.irs.gov/OrderForms to place an order and have Form W-7 and/or SS-4 mailed to you within 10 business days.

If you are asked to complete Form W-9 but do not have a TIN, apply for a TIN and write "Applied For" in the space for the TIN, sign and date the form, and give it to the requester. For interest and dividend payments, and certain payments made with respect to readily tradable instruments, generally you will have 60 days to get a TIN and give it to the requester before you are subject to backup withholding on payments. The 60-day rule does not apply to other types of payments. You will be subject to backup withholding on all such payments until you provide your TIN to the requester.

Note: Entering "Applied For" means that you have already applied for a TIN or that you intend to apply for one soon.

Caution: A disregarded U.S. entity that has a foreign owner must use the appropriate Form W-9.

Part II. Certification

To establish to the withholding agent that you are a U.S. person, or resident alien, sign Form W-9. You may be requested to sign by the withholding agent even if item 1, 4, or 5 below indicates otherwise.

For a joint account, only the person whose TIN is shown in Part I should sign (when required). In the case of a disregarded entity, the person identified on line 1 must sign. Exempt payees, see *Exempt payee code*, earlier.

Signature requirements. Complete the certification as indicated in items 1 through 5 below.

1. Interest, dividend, and barter exchange accounts opened before 1984 and broker accounts considered active during 1983. You must give your correct TIN, but you do not have to sign the certification.
2. Interest, dividend, broker, and barter exchange accounts opened after 1983 and broker accounts considered inactive during 1983. You must sign the certification or backup withholding will apply. If you are subject to backup withholding and you are merely providing your correct TIN to the requester, you must cross out item 2 in the certification before signing the form.
3. Real estate transactions. You must sign the certification. You may cross out item 2 of the certification.
4. Other payments. You must give your correct TIN, but you do not have to sign the certification unless you have been notified that you have previously given an incorrect TIN. "Other payments" include payments made in the course of the requester's trade or business for rents, royalties, goods (other than bills for merchandise), medical and health care services (including payments to corporations), payments to a nonemployee for services, payments made in settlement of payroll card and third party network transactions, payments to certain fishing boat crew members and fishermen, and gross proceeds paid to attorneys (including payments to corporations).
5. Mortgage interest paid by you, acquisition or abandonment of secured property, cancellation of debt, qualified tuition program payments (under section 529), ABLE accounts (under section 529A), IRA, Coverdell ESA, Archer MSA or HSA contributions or distributions, and pension distributions. You must give your correct TIN, but you do not have to sign the certification.

What Name and Number To Give the Requester

For this type of account:	Give name and SSN of:
1. Individual	The individual
2. Two or more individuals (joint account) other than an account maintained by an FFI	The actual owner of the account or, if combined funds, the first individual on the account ¹
3. Two or more U.S. persons (joint account maintained by an FFI)	Each holder of the account
4. Custodial account of a minor (Uniform Gift to Minors Act)	The minor ²
5. a. The usual revocable savings trust (grantor is also trustee) b. So-called trust account that is not a legal or valid trust under state law	The grantor-trustee ¹ The actual owner ¹
6. Sole proprietorship or disregarded entity owned by an individual	The owner ³
7. Grantor trust filing under Optional Form 1099 Filing Method 1 (see Regulations section 1.671-4(b)(2)(i)(A))	The grantor ⁴
For this type of account:	Give name and EIN of:
8. Disregarded entity not owned by an individual	The owner
9. A valid trust, estate, or pension trust	Legal entity ²
10. Corporation or LLC electing corporate status on Form 8832 or Form 2553	The corporation
11. Association, club, religious, charitable, educational, or other tax-exempt organization	The organization
12. Partnership or multi-member LLC	The partnership
13. A broker or registered nominee	The broker or nominee

For this type of account:	Give name and EIN of:
14. Account with the Department of Agriculture in the name of a public entity (such as a state or local government, school district, or prison) that receives agricultural program payments	The public entity
15. Grantor trust filing under the Form 1041 Filing Method or the Optional Form 1099 Filing Method 2 (see Regulations section 1.671-4(b)(2)(ii)(B))	The trust

- ¹ List first and circle the name of the person whose number you furnish. If only one person on a joint account has an SSN, that person's number must be furnished.
 - ² Circle the minor's name and furnish the minor's SSN.
 - ³ You must show your individual name and you may also enter your business or DBA name on the "Business name/disregarded entity" name line. You may use either your SSN or EIN (if you have one), but the IRS encourages you to use your SSN.
 - ⁴ List first and circle the name of the trust, estate, or pension trust. (Do not furnish the TIN of the personal representative or trustee unless the legal entity itself is not designated in the account title.) Also see *Special rules for partnerships*, earlier.
- *Note: The grantor also must provide a Form W-9 to trustee of trust.
Note: If no name is circled when more than one name is listed, the number will be considered to be that of the first name listed.

Secure Your Tax Records From Identity Theft

Identity theft occurs when someone uses your personal information such as your name, SSN, or other identifying information, without your permission, to commit fraud or other crimes. An identity thief may use your SSN to get a job or may file a tax return using your SSN to receive a refund.

- To reduce your risk:
- Protect your SSN.
 - Ensure your employer is protecting your SSN, and
 - Be careful when choosing a tax preparer.
- If your tax records are affected by identity theft and you receive a notice from the IRS, respond right away to the name and phone number printed on the IRS notice or letter.
- If your tax records are not currently affected by identity theft but you think you are at risk due to a lost or stolen purse or wallet, questionable credit card activity or credit report, contact the IRS Identity Theft Hotline at 1-800-908-4490 or submit Form 14039.
- For more information, see Pub. 5027, Identity Theft Information for Taxpayers.

Victims of identity theft who are experiencing economic harm or a systemic problem, or are seeking help in resolving tax problems that have not been resolved through normal channels, may be eligible for Taxpayer Advocate Service (TAS) assistance. You can reach TAS by calling the TAS toll-free case intake line at 1-877-777-4778 or TTY/TDD 1-800-829-4059.

Protect yourself from suspicious emails or phishing schemes. Phishing is the creation and use of email and websites designed to mimic legitimate business emails and websites. The most common act is sending an email to a user falsely claiming to be an established legitimate enterprise in an attempt to scam the user into surrendering private information that will be used for identity theft.

The IRS does not initiate contacts with taxpayers via emails. Also, the IRS does not request personal detailed information through email or ask taxpayers for the PIN numbers, passwords, or similar secret access information for their credit card, bank, or other financial accounts.

If you receive an unsolicited email claiming to be from the IRS, forward this message to phishing@irs.gov. You may also report misuse of the IRS name, logo, or other IRS property to the Treasury Inspector General for Tax Administration (TIGTA) at 1-800-366-4484. You can forward suspicious emails to the Federal Trade Commission at spam@uce.gov or report them at www.ftc.gov/complaint. You can contact the FTC at www.ftc.gov/idtheft or 877-IDTHEFT (877-438-4338). If you have been the victim of identity theft, see www.IdentityTheft.gov and Pub. 5027.

Visit www.irs.gov/identitytheft to learn more about identity theft and how to reduce your risk.

Privacy Act Notice

Section 6109 of the Internal Revenue Code requires you to provide your correct TIN to persons (including federal agencies) who are required to file information returns with the IRS to report interest, dividends, or certain other income paid to you; mortgage interest you paid; the acquisition or abandonment of secured property; the cancellation of debt; or contributions you made to an IRA, Archer MSA, or HSA. The person collecting this form uses the information on the form to file information returns with the IRS, reporting the above information. Routine uses of this information include giving it to the Department of Justice for civil and criminal litigation and to cities, states, the District of Columbia, and U.S. commonwealths and possessions for use in administering their laws. The information also may be disclosed to other countries under a treaty, to federal and state agencies to enforce civil and criminal laws, or to federal law enforcement and intelligence agencies to combat terrorism. You must provide your TIN whether or not you are required to file a tax return. Under section 3406, payers must generally withhold a percentage of taxable interest, dividend, and certain other payments to a payee who does not give a TIN to the payer. Certain penalties may also apply for providing false or fraudulent information.



VENDOR INFORMATION FORM

Please fill in:

Business Name _____

IRS Reporting Name _____

Business Address _____

City _____ State _____ Zip _____

Telephone () _____ Extension _____

Toll Free Number 800 _____

Vendor Fax Number _____

Vendor Email Address _____

Ordering Address _____

City _____ State _____ Zip _____

Telephone () _____ Extension _____

Remit Address _____

City _____ State _____ Zip _____

Telephone () _____ Extension _____

Contact Person: (Ordering) _____

Remit _____

PLEASE INCLUDE THE ABOVE INFORMATION
WHEN SUBMITTING YOUR BID OR PROPOSAL

NOTE: Sections 181.23 and 185.04 of The Codified Ordinances of Cleveland, Ohio 1976 require that this affidavit, properly executed and containing all required information, accompany your bid. IF YOU FAIL TO COMPLY, YOUR BID WILL NOT BE CONSIDERED.

STATE OF _____

COUNTY OF _____

}

SS

AFFIDAVIT

_____ being first

duly sworn deposes and says:

Individual only: That he/she is an individual doing business under the name _____

at _____, in

the City of _____, State of _____

Partnership only: That he/she is the duly authorized representative of a partnership doing business under the name of _____, in

the City of _____, State of _____

Corporation only: That he/she is the duly authorized, qualified and acting _____ of _____,

a corporation organized and existing under the laws of the State of _____; and that said individual, said partnership or said corporation, is filling herewith a bid to the City of Cleveland in conformity with the foregoing specifications;

Individual only: Affiant further says that the following is a complete and accurate list of the names and addresses of all persons interested in said proposed contract: _____

Affiant further says that he/she is represented by the following attorneys:

and is also represented by the following resident agents in the City of Cleveland:

Partnership only: Affiant further says that the following is a complete and accurate list of names and addresses of the members of said partnership: _____

Affiant further says that said partnership is represented by the following attorneys:

and is also represented by the following resident agents in the City of Cleveland:

ITEM 4

Corporation only: Affiant further says that the following is a complete and accurate list of the officers, directors and attorneys of said corporation:

President

Directors:

Vice President

Secretary

Treasurer

Cleveland Manager or Agent

Attorneys

And that the following officers are duly authorized to execute contracts on behalf of said corporation:

Affiant further says that the bid filed herewith is not made in the interest of or on behalf of any undisclosed person, partnership, company, association, organization or corporation; that such bid is genuine and not collusive or sham; that said bidder has not, directly or indirectly, induced or solicited any other bidder to put in a false or sham bid, and has not, directly or indirectly, colluded, conspired, connived or agreed with any bidder or anyone else to put in a sham bid, or that anyone shall refrain from bidding; that said bidder has not in any manner, directly or indirectly, sought by agreement, communication or conference with anyone to fix the bid price of said bidder or any other bidder, or to fix any overhead, profit, or cost element of such bid price or that of any other bidder, or to secure any advantage against the City of Cleveland or anyone interested in the proposed contract; that all statements contained in such bid are true; that said bidder has not, directly or indirectly, submitted his bid price or any break-down thereof or the contents thereof, or divulged information or data relative thereto, or paid or agreed to pay, directly or indirectly, any money, or other valuable consideration for assistance or aid rendered or to be rendered in procuring or attempting to procure the contract above referred to, to any corporation, partnership, company, association, organization, or to any member or agent thereof, or to any other individual, except to such person or persons as hereinabove disclosed to have a partnership or other financial interest with said bidder in his general business; and further that said bidder will not pay or agree to pay, directly or indirectly, any money or other valuable consideration to any corporation, partnership, company, association, organization or to any member or agent thereof, or to any other individual, for aid

or assistance in securing contract above referred to in the event the same is awarded to _____

(name of individual, partnership or corporation)

Further affiant said not.

(Sign Here) _____

Sworn to before me and subscribed in my presence this _____ day of _____,

20 _____

Notary Public

CITY OF CLEVELAND

BID BOND

KNOW ALL MEN BY THESE PRESENTS, That we

as Principal, and

a corporation duly authorized to do business in Ohio, as Surety, are held and firmly bound unto

THE CITY OF CLEVELAND

as Obligee, in the penal sum of _____

Dollars, lawful money of the United States of America, for the payment of which, well and truly to be made, we bind ourselves, our heirs, executors, administrators, successors and assigns, jointly and severally, firmly by these presents.

SIGNED, sealed and dated this _____ day of _____, 20_____.

WHEREAS, the said principal is herewith submitting bid for

Now, THEREFORE, the condition of the above obligation is such that if the said principal shall execute a contract and give bond for the faithful performance within ten (10) working days after being notified in writing of the award of such contract to the principal, or if the principal or surety shall pay the obligee the sum, not exceeding the penalty hereof, by which the amount of the contract, covering the said proposal, properly and lawfully executed by and between the obligee and some third party, may exceed the amount bid by principal, then this obligation shall be void; otherwise it shall remain in full force and effect.

PRINCIPAL _____

BY: _____

TITLE _____

By _____
Attorney in Fact

CITY OF CLEVELAND

BID FORM

STANDARD CONTRACT BID
 REQUIREMENT CONTRACT BID

TO: The Commissioner of Purchases and Supplies:

BID FOR Adjustable Valve Boxes & Appurtenances

FOR: The Department of: Public Utilities, Division of Water

The Undersigned proposes to furnish the above articles, commodities, materials, supplies, equipment or services ("items"), and to accept as full compensation therefor the price per unit multiplied by the number of units of such items purchased hereunder, (which units and prices therefor are set forth in the Schedule of Items hereto attached and made part of this bid) and subject to any discount set forth in this bid.

The Undersigned further proposes to execute the Contract Agreement and to furnish satisfactory performance bond within ten (10) working days, excluding Saturdays, Sundays and holidays, after notice of award of contract has been received.

The Undersigned further certifies that he (as the individual, firm or corporation making this bid) is not in arrears or default to the City of Cleveland upon any debt or contract, nor is a defaulter as surety or otherwise upon any obligation to said City, nor has failed to perform faithfully any previous contract with said City and that there is no suit or claim pending as to any such arrears or default.

The Undersigned deposits with the bid a Bid Bond to the City of Cleveland signed by a surety company authorized to do business in Ohio, in the sum of \$ _____

or a cashier's check or certified check on a solvent bank in the sum of \$ _____ payable to the City of Cleveland, as security that if he be awarded the contract, he will enter into a written contract and secure the performance of the same by a bond as required of an approved surety company authorized to do business in Ohio and satisfactory to the Director of Law, in the sum equal to the percentage of the total price bid set forth in Part B – General Conditions and in conformity with the provisions of The Codified Ordinances of Cleveland, Ohio 1976.

The Undersigned further agrees that if the bid is accepted and contract awarded and he shall fail to execute said contract and furnish the satisfactory bond, as required, within the time above specified, then the City may, at its option, declare the contract abandoned and this bid null and void. Thereupon the penal sum of the Bid Bond shall become due to the City, or the certified or cashier's check shall be forfeited to and become the property of the City as liquidated damages. Otherwise, the Bid Bond or the certified or cashier's check, or the amount of such check shall be returned to the Undersigned.

THE UNDERSIGNED UNDERSTANDS THAT THE CITY RESERVES THE RIGHT TO REJECT ANY OR ALL BIDS.

The firm, corporation, or individual name
MUST BE SIGNED IN SPACE INDICATED.
ERASURES MAY INVALIDATE THIS BID.

Complete: CORPORATION OR FIRM

Sign Here By _____

If the bidder is a firm or corporation, the title
of the officer signing and the State in which
Incorporated must be indicated.

TITLE OF OFFICER

BUSINESS ADDRESS OF BIDDER

STATE OF INCORPORATION

BID - SCHEDULE OF ITEMS				BID PAGE 1 of 3	
City of Cleveland Division of Purchases And Supplies					
128 City Hall Cleveland, Ohio 44114				BIDDER MUST COMPLETE & SIGN BELOW	
TITLE OF BID ADJUSTABLE VALVE BOXES & APPURTENANCES				NAME OF FIRM	
				STREET ADDRESS	
ORDINANCE NO. 129.25	PASSED September 21, 1992	SIGNED September 25, 1992			
DEPARTMENT PUBLIC UTILITIES		DIVISION WATER			
CITY RECORD ADVERTISEMENT DATES		<input type="checkbox"/> STANDARD CONTRACT BID <input checked="" type="checkbox"/> REQUIREMENT CONTRACT BID		AUTHORIZED SIGNATURE	
BUYER: (216) 664-2620 purchasing@clevelandohio.gov		BID OPENING	12:00 O'CLOCK NOON Official Time	DATE	
DESCRIPTION			QUANTITY	UNIT PRICE	EXTENSION
Adjustable Valve Boxes:					
Location of Factory or Foundry: _____					
1. Adj. cast iron valve box, base No. 2 or No. 3, as specified Name of Manufacturer: _____		Price	1,000 Each	\$ _____	\$ _____
2. Adj. cast iron valve box, alternate bottom No. 1, as specified Name of Manufacturer: _____		Price	50 Each	\$ _____	\$ _____
3. Adjustable cast iron valve box extension, as specified Name of Manufacturer: _____		Price	50 Each	\$ _____	\$ _____
NOTE: Bidders will be required to furnish a bid price on both items 2 and 3. Failure to furnish a bid price on both items will be cause for a rejection of both items.					
4. Adjustable cast iron valve box, round cast iron cover (for No. 2 top), as specified Name of Manufacturer: _____		Price	400 Each	\$ _____	\$ _____
5. Adjustable cast iron valve box (plain) top No.1 or No. 2 (for round cover), as specified Name of Manufacturer: _____		Price	400 Each	\$ _____	\$ _____
6. Adjustable cast iron valve box (tri-skirt) top No.1 or No. 2 (for round cover), as specified Name of Manufacturer: _____		Price	50 Each	\$ _____	\$ _____
ALL QUANTITIES ARE APPROXIMATE AMOUNTS. THE CONTRACT, IF ANY, SHALL BE EFFECTIVE FOR A PERIOD OF ONE (1) YEAR. ALL OF THIS BOUND INFORMATION MUST BE KEPT INTACT AND TOGETHER WITH ANY ADDENDA ISSUED, AND MUST BE RETURNED WITH THE BID. OTHERWISE, THE BID MAY BE CONSIDERED INFORMAL.				DELIVERY (Days)	PAYMENT DISCOUNT
				% Days	

BID - SCHEDULE OF ITEMS

City of Cleveland

BID PAGE 2 of 3

**BIDDER MUST
SIGN AND DATE BELOW**

AUTHORIZED SIGNATURE

TITLE OF BID

ADJUSTABLE VALVE BOXES & APPURTENANCES

DATE

DESCRIPTION	QUANTITY	UNIT PRICE	EXTENSION
7. Adj. cast iron valve box, alt. long top No. 1 or alt. long top No. 2, complete with cast iron round alt. cover No.1 or cast iron round alternate cover No. 2, as spec. <div style="text-align: right; margin-right: 50px;">Price (Top & Cover)</div> Name of Manufacturer: _____	1,000 Each	\$ _____	\$ _____
Risers: Location of Factory or Foundry: _____			
8. New style, cast iron, round, 1" riser, as specified <div style="text-align: right; margin-right: 50px;">Price</div> Name of Manufacturer: _____	50 Each	\$ _____	\$ _____
9. New style, cast iron, round, 1½" riser, as specified <div style="text-align: right; margin-right: 50px;">Price</div> Name of Manufacturer: _____	50 Each	\$ _____	\$ _____
10. New style, cast iron, round, 2" riser, as specified <div style="text-align: right; margin-right: 50px;">Price</div> Name of Manufacturer: _____	50 Each	\$ _____	\$ _____
11. New style, cast iron, round, 2½" riser, as specified <div style="text-align: right; margin-right: 50px;">Price</div> Name of Manufacturer: _____	25 Each	\$ _____	\$ _____
12. New style, cast iron, round, 3" riser, as specified <div style="text-align: right; margin-right: 50px;">Price</div> Name of Manufacturer: _____	50 Each	\$ _____	\$ _____
13. Old Style Riser No. 2, round, 1", as specified <div style="text-align: right; margin-right: 50px;">Price</div> Name of Manufacturer: _____	50 Each	\$ _____	\$ _____
14. Old Style Riser No. 2, round, 1½", as specified <div style="text-align: right; margin-right: 50px;">Price</div> Name of Manufacturer: _____	50 Each	\$ _____	\$ _____
ALL QUANTITIES ARE APPROXIMATE AMOUNTS. THE CONTRACT, IF ANY, SHALL BE EFFECTIVE FOR A PERIOD OF ONE (1) YEAR. BIDDER MUST SIGN AND DATE THIS SHEET		DELIVERY (Days)	PAYMENT DISCOUNT % Days
FOR PURCHASING USE ONLY			

BID - SCHEDULE OF ITEMS

City of Cleveland

BID PAGE 3 of 3

**BIDDER MUST
SIGN AND DATE BELOW**

TITLE OF BID

ADJUSTABLE VALVE BOXES & APPURTENANCES

AUTHORIZED SIGNATURE

DATE

DESCRIPTION	QUANTITY	UNIT PRICE	EXTENSION
15. Old Style Riser No. 2, round, 2", as specified Name of Manufacturer: _____ Price	50 Each	\$ _____	\$ _____
16. Old Style Riser No. 2, round, 2½", as specified Name of Manufacturer: _____ Price	50 Each	\$ _____	\$ _____
17. Old Style Riser No. 2, round, 3", as specified Name of Manufacturer: _____ Price	20 Each	\$ _____	\$ _____
18. Riser No. 3, square, 1", as specified Name of Manufacturer: _____ Price	20 Each	\$ _____	\$ _____
19. Riser No. 3, square, 1½", as specified Name of Manufacturer: _____ Price	40 Each	\$ _____	\$ _____
20. Riser No. 3, square, 2", as specified Name of Manufacturer: _____ Price	40 Each	\$ _____	\$ _____
21. Riser No. 3, square, 2½", as specified Name of Manufacturer: _____ Price	15 Each	\$ _____	\$ _____
22. Riser No. 3, square, 3", as specified Name of Manufacturer: _____ Price	15 Each	\$ _____	\$ _____
23. Riser No. 5, oval, 2", as specified Name of Manufacturer: _____ Price	10 Each	\$ _____	\$ _____

Total For All Items Bid: \$ _____

ALL QUANTITIES ARE APPROXIMATE AMOUNTS. THE CONTRACT, IF ANY, SHALL BE EFFECTIVE FOR A PERIOD OF ONE (1) YEAR.

BIDDER MUST SIGN AND DATE THIS SHEET

DELIVERY
(Days)

PAYMENT DISCOUNT

% Days

FOR PURCHASING USE ONLY

GENERAL CONDITIONS

- B-1 CONSIDERATION OF BIDS.**
All bids received in conformity with the Invitation to Bid shall be endorsed with the contract or advertisement name or number and name and address of the bidder. All bids, immediately after being read, shall be tabulated and summarized and shall become public record in the office of the Commissioner of Purchases and Supplies.
- B-2 UNACCEPTABLE BIDS.**
No bid will be accepted from, nor a contract awarded to, any person, firm or corporation that is in arrears or is in default to the City upon any debt or contract, or is a defaulter as surety or otherwise upon any obligation to the City, or has failed to perform faithfully on any previous contract with the City of Cleveland.
- B-3 REJECTION OR ACCEPTANCE OF BIDS.**
The City through the Board of Control shall have the right to reject any or all bids, parts of such bid, and reserves the right to waive any informalities in the bid. In addition to bid price and discount, the City reserves the right to consider all elements entering into the question of determining the responsibility of the bidder. Any bid which is incomplete, conditional, obscure, contains additions not called for, or irregularities of any kind, may be cause for rejection of the bid.
- B-4 EVIDENCE OF ABILITY TO FULFILL CONTRACT.**
Bidders must present evidence to the Commissioner of Purchases and Supplies, when required by him to do so, to show they are fully competent and have the necessary source of supply, facilities and pecuniary resources to fulfill the conditions of the contract and specifications.
- B-5 WITHDRAWAL OF BID.**
No bid may be withdrawn after it has been deposited with the Commissioner of Purchases and Supplies.
- B-6 TIME OF AWARD.**
The Board of Control of the City of Cleveland shall make an award or reject all bids not later than the second regular meeting of said Board following the opening of bids, unless further time is required to analyze bids, to investigate responsibility of any bidder, or in the absence of a time limitation for acceptance set forth in the bid.
Any extension of time beyond the date fixed by the successful bidder or the fourth regular meeting of the Board of Control, whichever event shall occur first, shall be subject to agreement between said bidder and the Board.
- B-7 AWARD CONTRACT.**
No contract shall be awarded without the approval of the Board of Control, and then only to the lowest and best bidder.

B-8 PERFORMANCE BOND.

A. Contracts for the purchase of articles, supplies, commodities, materials, equipment or services shall be secured by a bond in the form and content prescribed by and acceptable to the Director of Law, with good and sufficient sureties and in an amount equal to at least twenty-five percent (25%) of the contract price on materials supplied and at least fifty percent (50%) of the contract price on services supplied. A check is not acceptable in place of a performance bond. A performance bond is not required for standard purchase and requirements contracts awarded in the amount of \$500,000.00 or less, except that standard purchase and requirements contracts that are labor and materials contracts including, but not limited to painting, carpentry, plumbing, electrical, masonry, landscaping, snow plowing, fencing and trucking over \$100,000 but not more than \$250,000 shall require a bond of at least twenty-five percent of the contract price, and over \$250,000 but not more than \$500,000 shall require a bond of at least fifty percent of the contract price. The above policy notwithstanding, the City of Cleveland reserves the right to require a performance bond in various amounts or to modify the performance bond requirement whenever it is determined to be in the best interest of the City of Cleveland to do so.

B. No performance bond is required for any contract awarded pursuant to this Invitation to Bid in an amount of \$500,000.00 or less. Any contract over \$500,000.00 will require a Performance Bond for 25% of the contract amount.

B-9 RELEASE OF BOND.

Whenever a performance bond is required, the performance bond will not be released until all the provisions of the contract have been fulfilled.

B-10 CANCELLATION OF CONTRACT.

The City shall have the right to cancel this contract on five (5) days written notice if, in the opinion the Commissioner of Purchases and Supplies, the delivery of materials, supplies or equipment or the performance of work or services are not in accordance with contract specifications and the contractor fails to cure such deficiencies or comply with the contract specifications within ten (10) days after receipt of notice of default from the City, except where fulfillment of its obligation requires activity over a period of time and it has, within ten (10) days of the default notice commenced such activity. Additionally, the City shall have the right to cancel this contract, without cause, upon fifteen (15) days written notice upon the determination of the Board of Control of the City, expressed through its resolution, to do so.

B-11 SUBCONTRACTING OR ASSIGNMENT OF CONTRACT.

a. The contractor shall not subcontract, sublet, assign, transfer, convey or otherwise dispose of the contract, its duties, rights, title or interest in it or in any part thereof, or assign, by power of attorney or otherwise, any of the monies due or to become due under the contract, except, in each instance, with the prior written authorization of the Board of Control of the City, expressed through its resolution, and then only upon such terms and conditions as may be agreed to by said Board. No such subcontracting, subletting, assignment, transfer, conveyance or other disposal of the contract shall be valid until filed in the office of the Commissioner of Accounts.

b. Prior written Board of Control consent is required for a City contractor to add a subcontractor, or to substitute one subcontractor for another subcontractor, under a City contract.

c. The City assumes no obligation to pay, and will not pay, a contractor for any work and or services performed by a sub-contractor on the contract prior to Board of Control approval of that sub-contractor.

d. The Director will not grant any City contractor additional time to meet project deadlines, and will not authorize or pay additional compensation or delay damages of any kind arising from the contractor's inability to add or substitute a subcontractor because the contractor failed to submit the approval request and supporting documentation at least 3 (three) weeks in advance of the date the additional or substitute sub-contractor is needed.

e. The Office of Equal Opportunity shall evaluate each subcontractor addition and substitution for increased CSB, MBE, or FBE participation even if the original contract had no certified sub-contractor participation.

f. The City's Sub-contractor Addition and Substitution Policy and Procedure is hereby incorporated by reference in its entirety. The complete document is available online at the City of Cleveland website: <http://www.city.cleveland.oh.us>.

B-12 DELAY FOR CAUSES BEYOND CONTROL.

If the contractor is delayed in complying with the terms of the contract by strikes, lockouts, fire, unusual delay by common carriers, unavoidable casualties, or any cause beyond the contractor's control including orders, limitations or restrictions of any Governmental agency having jurisdiction over the subject matter of the contract, or by delay authorized by the City, or for any cause by which the director shall decide to justify the delay; then for all such delays and suspensions, the contractor shall be allowed one calendar day extension beyond the time fixed for compliance with the terms of the contract for each and every calendar day of such delay so caused in the completion of the work, the same to be ascertained by the director.

B-13 PATENTS.

The Contractor shall be required to pay all royalties and license fees and shall hold and save the City and its officers, agents, servants and employees harmless from liability of any nature or kind, including cost and expenses, for or on account of any patented or unpatented invention, process, article, or appliance manufactured or used in the performance of the contract, including its use by the City of Cleveland unless otherwise specifically stipulated in the contract documents. In this respect the contractor shall defend all suits or claims for infringement of any patent or license rights.

B-14 DELIVERY.

The vendor shall adhere to all stipulated delivery terms (e.g., material / service delivery upon a pre-set schedule, upon orders being placed, etc.). All service performance / material deliveries should be made only if the City of Cleveland has issued a valid, open Purchase Order (PO) with a sufficient free balance to

cover the full costs of the service being performed or materials being delivered. The City will not pay vendors for goods or services that are either delivered to the City under an invalid or unauthorized PO or were ordered using an expired contract. The City is not responsible for, and will not pay for, goods or services delivered to the City that are not authorized under the PO and contract under which a sale was purportedly made. Therefore, the vendor must not perform any services nor deliver any materials without a valid, open PO that authorizes the services / materials and that carries a sufficient free balance to cover the services / materials.

Upon delivery, some form of delivery documentation must be left with the City of Cleveland Department. For service performed, some Proof of Service documentation must be given to a City employee. For materials delivered, some Proof of Delivery or Packing Slip must be given to a City employee. In all instances, the delivery documentation must be signed and dated by a City employee in order to substantiate the services provided or materials delivered were as indicated on the documentation. City employees are charged with performing this verification, so vendors should allow adequate time for this review to occur. Failure to provide some delivery documentation, which received a City signature and date upon delivery, may result in payment delays.

B-15 LABORATORY TEST.

The City of Cleveland reserves the right to test all materials, equipment or supplies delivered during the life of the contract, at an independent laboratory to be designated by the Commissioner of Purchases and Supplies of the City of Cleveland. Where the result of such test shows the materials, equipment or supplies are not equal to the specifications, then the expense of making such test shall be paid by the contractor.

B-16 FAILURE TO MEET SPECIFICATIONS.

The delivery of any material, supplies or equipment or the performance of any work or services under the contract which do not conform to contract specifications will be rejected and the contractor notified immediately in writing of such rejection and the reason therefore. If the time for performance has not expired, and the contractor wishes to remedy the deficient materials, supplies or equipment or performance, it may notify the Commissioner of Purchases and Supplies of its intention to cure and may within ten (10) days make a conforming delivery of performance unless such time is extended in writing by said Commissioner. If said contractor fails to replace such nonconforming materials, supplies or equipment or otherwise cure such deficient performance of work or services, the City of Cleveland will purchase such materials, supplies or equipment or obtain the performance of such work or services of the character required on the open market or in case of work and services, by performance by City employees. In such event, the contractor and his surety shall be liable to the City for any excess costs and expenses thereby incurred.

B-17 SAFEGUARDS.

Any equipment to be furnished by the terms of this bid, shall be provided with safety controls, guards, and housing meeting the requirements of the safety standards of the Industrial Commission and the Department of Industrial Relations of Ohio, and the cost shall be included as part of the bid.

B-18 STATE OR FEDERAL TAXES.

- a. The City of Cleveland is exempt from all sales, excise and transportation taxes, except State of Ohio gasoline tax. The price or prices bid shall be exclusive of all such taxes and will be so construed.
- b. The contract price is subject to increase by the amount of any additional tax imposed by the Federal Government or the State of Ohio subsequent to the receipt of bids. Such claim for increased prices must be presented to the City within thirty (30) days after such tax becomes effective and supported by evidence satisfactory to the Director of Law.
- c. The contract price is subject to reduction by that amount by which an applicable tax is reduced during the period of the contract.

B-19 SOCIAL SECURITIES ACT/EMPLOYEES BENEFIT PAYMENTS.

The contractor shall be and remain an independent contractor with respect to all services performed under said contract, and agrees to and accepts full and exclusive liability for the payment of any and all contributions or taxes for social security, unemployment insurance, old age retirement benefits, pensions, or annuities now or hereafter imposed under any state or federal law, which are measured by the terms of this contract and further agrees to obey all lawful rules and regulations and to meet all lawful requirements which are now or hereafter may be issued or promulgated under said respective laws by and duly authorized state or federal officials and said contractor also agrees to indemnify and save harmless the City of Cleveland from an such contributions or taxes or liability therefore.

B-20 FREIGHT ON DIRECT SHIPMENTS TO THE CITY.

The freight prices made in the bid are to be in accordance with lawful freight or cartage charges in existence at the time the bid is made, and contract prices shall be increased or decreased by changes in the freight or cartage rates, provided that claims for additional freight or cartage be presented to the City of Cleveland within thirty (30) days after said advance in freight or cartage rates becomes effective. Reductions in freight or cartage prices will be deducted from the contract price.

B-21 INVOICING AND PAYMENT.

The Contractor shall submit invoices that appropriately reflect the work performed. Original invoices must be typed and legible. The City of Cleveland does not pay from duplicates or copies. Each invoice must be mailed as specified below:

- Original invoice to address as shown on Purchase Order under "BILL TO:"
- Optional: Copy of invoice to the City of Cleveland, Division of Accounts, 601 Lakeside Avenue, Cleveland, OH 44114, clearly marked "COPY".
- Address invoice questions first to the ordering department. The Division of Accounts will assist if the Department is unable to resolve the question.

The failure to deliver copies of invoices to the indicated location may lead to delays in payment.

Invoices submitted by the Contractor for payment must include the following information:

- Contractor Name, as it appears on the Contract;
- Contractor Mailing Address;
- Contractor Telephone Number;
- Contractor Facsimile Number;
- Contract Number;
- Purchase Order (PO) Number under which the work being invoiced was authorized;
- Contractor Invoice Number, which must be a unique (non-recurring) number;
- Invoice Date, reflecting the date that the invoice itself was issued to ;
- Timeframe that the invoice covers;
- A detailed itemization of labor and materials provided, including:
 - Date that work was performed / material delivered,
 - Location for each item of service performed / material delivered,
 - Line Item Number from the Contract's Schedule of Items (SOI) that is being invoiced,
 - Quantity of items being invoiced under each Line Item,
 - Unit Cost of each Line Item,
 - Extended Cost by each Line Item.
- delivery documentation (e.g., Proof of Service / Delivery slip, Packing Slip, etc.) with an acknowledgement signature and date from a City of Cleveland employee;

The City of Cleveland is not subject to sales tax per Section 5739.01 (B)(1) O.R.C. Therefore invoices must not charge sales tax. The City's Tax Exemption Number is 34-6000646. Tax Exemption Certificates are available upon request from the Division of Purchases and Supplies.

Any applicable discounts, as stipulated through the contract and/or PO, must be itemized and applied to the invoice. Any special instructions contained within the contract must also be followed.

If any invoice is erroneous or does not include the above required information, the City shall inform the supplier as to the reasons thereof and any corrective actions necessary to qualify the invoice for payment by the City. The vendor is responsible for providing the delivery documentation at the time of delivery and for submitting the invoice.

B-22 EQUAL OPPORTUNITY.

This contract is a contract, and contractor is a contractor within the meaning of Chapter 187 of the Codified Ordinances of Cleveland, Ohio 1976. During the term, the contractor shall comply with all terms, conditions and requirements imposed on "contractor" in the Equal Opportunity Clause, Section 187.22(b) of

the Codified Ordinances of Cleveland, Ohio 1976, attached hereto and made a part hereof. A copy of such clause shall be made a part of every subcontract of agreement entered into for goods or services and shall be binding on all persons, firms and corporations with whom the contractor may deal.

PARAGRAPHS B-23 AND B-24 APPLY ONLY IF THE REQUIREMENT CONTRACT BID BLOCK IS MARKED ON BID PAGE 1 OF BID AND ON BID FORM.

B-23 DURATION OF CONTRACT.

The proposed contract shall be effective upon its execution and approval by the Director of Law of the City of Cleveland and, for the purpose of accepting delivery, shall continue in full force and effect for the period specified in the specifications and/or the Schedule of Items section of the bid, unless otherwise indicated.

B-24 REDUCTION IN PRICES.

The contractor agrees that if the price to the general trade is reduced while the contract is in effect, the City of Cleveland will receive the benefit of such reduction immediately. However, if the contract price is below the price to the general trade at the time the contract is awarded, the reduction provision will be effective only when the recognized price to the general trade reaches a level lower than the contract price or when the contractor reduces his own price to a level lower than the contract price.

B-25 EIGHT-HOUR DAY, MINIMUM WAGE, AND NON-DISCRIMINATION.

The Contractor agrees that it shall comply with the following provisions of the Charter of the City of Cleveland, which are, respectively, as follows:

Section 196. Except in case of extraordinary emergencies; not to exceed eight (8) hours will constitute a day's work and not to exceed forty eight (48) hours a week's work, for any City employee of the City of Cleveland in the classified service thereof, and for any workmen engaged in public work carried on or aided by the municipality whether done by contract or otherwise. The Council shall by ordinance, provide for the enforcement of the provisions of this section.

Section 197. Every contract for public work entered into by the City of Cleveland shall contain, and no contract shall be entered into unless it contains the following stipulations:

The Contractor hereby agrees that all persons employed by him will be paid wages which are not less than are paid by the City of Cleveland for similar or like work; but if said City has not established a rate of wages for any particular class of work to be performed under the terms of this contract, then said employees shall be paid wages not less than are generally paid therefore by others employing union labor in said City.

The Contractor hereby further agrees that in the employment of labor, skilled or unskilled, under the Contract there will be no discrimination exercised against any citizen because of race, color, religion or national origin; and that any violation hereof shall be deemed a material breach of said contract.

B-26 LAWS, PERMITS, AND REGULATIONS

The contractor shall comply with all applicable laws of the Federal government, State, ordinances of the City or other municipality in which the work or services are being done and all applicable regulations and any authorized regulations, and shall be responsible for securing at his own expense any and all licenses, permits and certificates of inspection required by law or by the contract documents.

SERVICES, LABOR & MATERIALS – IF THIS CONTRACT IS FOR WORK, SERVICES, OR LABOR & MATERIALS, B-27, 28 AND B-29 APPLY

B-27 STATE INDUSTRIAL COMPENSATION FOR PURCHASE OF LABOR AND MATERIALS.

If this contract contains labor, whether in part or in all, the contractor shall, in all cases during the term of this contract, subscribe to and comply with the Worker's Compensation Laws of the State of Ohio and pay such premiums as may be required thereunder and to save said City harmless from any and all liability arising from said act. He shall also furnish at the time of delivery of this contract and such other times as may be requested, a copy of the official certificate or receipt showing the payments hereinbefore referred to. A copy of the official certificate or receipt showing the payments hereinbefore referred to, shall be submitted with the bid, or, if not included with the bid, shall be submitted with the signed contract. No work shall be commenced, or payments made, until the certificate or receipt is received by the City. The contractor shall maintain continuous coverage throughout the contract and shall notify the City in writing within 24 hours of receipt of notice of cancellation or reduction of coverage.

B-28 INDEMNITY

Contractor shall indemnify, defend, and hold harmless the City of Cleveland, Ohio, its officers, agents, and employees from all claims, demands, liabilities, loss, suits, causes of action, judgments, costs, and expenses, including attorneys' fees, arising, occurring, or allegedly arising or occurring from personal injury, including death, property damage, including loss of use, or otherwise, to any person or the property of any person, including third parties and employees of any party, as a result of negligent or intentional act or omission by Contractor or its agents, employees, subcontractors or suppliers, in performing work or services or furnishing labor and materials under this contract. This indemnification right is in addition to any other indemnification or contribution right of any indemnified party and shall survive completion of the work or services or furnishing of labor and materials.

B-29 WARRANTY

Contractor warrants, in addition to any other express or implied warranty required by law or the contract, that all work and services performed under this Agreement will be of good quality, free from faults and defects, conform to the contract documents, performed in a workmanlike manner according to good usage and

accepted practice, resulting in a merchantable product, and fit and suitable for their intended purpose, and that materials supplied will be of good quality and free from all defects, latent or patent.

B-30 OHIO CAMPAIGN FINANCE LAW

Pursuant to the Ohio Revised Code, as referenced below, the following language is hereby made a part of this document:

"Contractor hereby certifies that beginning on the date the contract is awarded and extending until one year following conclusion of the contract, all persons identified in Ohio Revised Code Sections 3517.13(I)(3) and 3517.13(J)(3), as applicable, are in compliance with Ohio Revised Code Sections 3517.13(I)(1) and 3517.13(J)(1)."

By submitting a signed sealed bid, those persons signing the document are affirming their compliance with the referenced sections of the Ohio Revised Code, herein incorporated into any contract created pursuant to this Invitation to Bid in its entirety.

B-31 TITLE 48 C.F.R. ETC:

Certification Re: Federal Debarment, Suspension, Ineligibility or Voluntary Exclusion; Title 48 Code of Federal Regulations, Part 9, and other regulations, preclude the City from participating in a covered transaction, as defined in subpart 9.4, with any agency, corporation, partnership, or other legal entity that has been debarred, suspended, proposed for debarment, declared ineligible, or voluntarily excluded by the Federal Government from participating in transactions involving Federal funds. By signing and submitting this document, the bidder certifies to City that it, its principals, any subcontractors, and subcontractor principals:

- 1) Are not presently debarred, suspended, proposed for debarment, declared ineligible, or voluntarily excluded by any Federal department or agency;
- 2) Have not within the three-year period immediately preceding the submission date of this document been convicted of or had a civil judgment rendered against them personally or the company for commission of fraud or a criminal offense in connection with obtaining, attempting to obtain, or performing a public (Federal, State or Local) transaction or contract under a public transaction; violation of Federal or State antitrust statutes or commission of embezzlement, theft, forgery, bribery, falsification or destruction of records, making false statements, or receiving stolen property;
- 3) Are not presently indicted for or otherwise criminally or civilly charged by a government entity (Federal, State or local) with commission of any of the offenses enumerated in paragraph (1)(b) of this certification; or,
- 4) Have not within the three-year period immediately preceding submission date of this document had one or more public transactions (Federal, State or local) terminated for cause or default.

If the bidder is unable to certify to any of these statements in this certification, such prospective participant must attach a written explanation to this bid. Failure or inability to certify to any of these statements may be cause for rejection of the bid.

The Federal Debarred Listing is available at <http://www.epls.gov/>

By submitting a signed sealed bid, those persons signing the document are affirming their compliance with the referenced sections of the Code of Federal Regulations, herein incorporated into any contract created pursuant to this Invitation to Bid in its entirety.

**SPECIFICATIONS/DESCRIPTIONS OF PRODUCTS AND/OR SERVICES
CITY OF CLEVELAND - DIVISION OF WATER
SECTION C – SUPPLEMENTAL GENERAL CONDITIONS**

ADJUSTABLE VALVE BOXES & APPURTENANCES

C-1 SCOPE

This specification shall cover adjustable valve boxes and appurtenances for the distribution system of the Cleveland Division of Water (CWD), for a term of one year.

C-2 CITY OF CLEVELAND FORMS

Failure to submit the following City of Cleveland (City) forms properly **will** cause your bid to be non-responsive.

- A. Bid Bond
 1. Use the City's Bid Bond form.
 2. Follow the instructions in Part B and C of the Bidder's Check List completely.
 3. A bid bond is not required if your total bid is \$50,000.00 or less.
- B. Bid Form
 1. Indicate whether you are submitting a bid bond or a cashier's check/certified check in the amount of 5% of your bid total.
 2. The information at the bottom of the page must be filled out completely and signed by an officer of the corporation or firm.
- C. Affidavit
 1. The first three lines of the affidavit must be filled out stating the state, county, and name of the person being sworn.
 2. The state on page one must be the same state as the notary's commission stamp that appears at the bottom of page two.
 3. The date notary's commission expires must be displayed by the notary at the bottom of page two unless state requirements differ.
 4. Be sure that the proper signature lines are used on page two for the person that is being sworn.
 5. Fill out all necessary information on both pages of the affidavit.

Any other forms that are included in the bid package should be filled out completely, signed where necessary, and returned.

C-3 PRE-BID MEETING/LAST DAY FOR QUESTIONS

- A. A pre-bid meeting will be held on the date and time as per the advertisement announcement. Bidders are cautioned that questions, clarifications, and information that may result from this meeting, could affect your bid. In addition, by City policy, this is the only opportunity for potential bidders to speak directly with CWD personnel prior to the award of the contract. Attendance at the pre-bid meeting is non-mandatory.
- B. The last day for questions is seven business days before the bid opening date. All questions should be submitted in writing to:

**SPECIFICATIONS/DESCRIPTIONS OF PRODUCTS AND/OR SERVICES
CITY OF CLEVELAND - DIVISION OF WATER
SECTION C – SUPPLEMENTAL GENERAL CONDITIONS**

ADJUSTABLE VALVE BOXES & APPURTENANCES

Division of Purchasing & Supplies
Email: purchasing@clevelandohio.gov
or via fax: (216) 664-2177.

C-4 APPROXIMATE QUANTITIES

The approximate quantities of adjustable valve boxes and appurtenances to be purchased under the terms of this requirement contract shall be as set forth on the attached Bid-Schedule of Items.

C-5 MATERIAL SPECIFICATIONS

All adjustable valve box parts including fixed risers shall be cast iron in conformance with this specification unless otherwise noted.

- A. CAST IRON: Cast iron shall conform to ASTM Specification A48 Standard Specification for Gray Iron Castings with no specific requirement as to class. Chemical composition will not be considered, but the material shall be of good quality and of such character as to make the metal of the castings strong, tough and of even grain. The metal must be made without any mixture of cinder iron or other inferior metal.

- B. CASTINGS: The iron adjustable valve box castings must be smooth, free from scales, lumps, blisters, sand holes and defects of every nature, which in the opinion of the Director of the Department of Public Utilities (DPU) or his designee make them unfit for the use for which they are intended. The castings shall be free from injurious defects, cracks, gas holes, flaws, and excessive shrinkage. No plugging or filling will be allowed. Inspection shall be visual inspection for appearance and surface smoothness in comparison with samples accepted as standard.

C-6 MATERIAL REQUIREMENTS

- A. The following drawings showing the adjustable valve box parts are attached to these specifications and made a part thereof:

Adjustable Valve Box Part	Number
Extension	SK-1236-A-1
Base No. 2 & 3	SK-1236-A-1
Alternate Bottom No. 1	SK-1236-A-2
Top No. 3 & No. 4 for Square Cover	SK-1236-B-1
Square Cover For No. 3 & 4 Top	SK-1236-B-2
Top No. 2 For Round Cover	SK-1236-B-3
Round Cover For No. 2 Top	SK-1236-B-4
Alternate Cover No. 1	SK-1236-B-5
Alternate Long Top No. 1	SK-1236-B-5

**SPECIFICATIONS/DESCRIPTIONS OF PRODUCTS AND/OR SERVICES
CITY OF CLEVELAND - DIVISION OF WATER
SECTION C – SUPPLEMENTAL GENERAL CONDITIONS**

ADJUSTABLE VALVE BOXES & APPURTENANCES

Adjustable Valve Box Part	Number
Alternate Cover No. 2	SK-1236-B-6
Alternate Long Top No. 2	SK-1236-B-6
5¼" Valve Box Riser	Page 18-19

- B. The adjustable valve boxes must conform to the dimensions as shown on the attached drawings.
- C. Covers
 - 1. All covers shall be interchangeable in tops of their respective boxes; such tops shall not project above the surface of the top section, nor shall they be recessed more than one-eighth of an inch.
 - 2. All covers must lie true in their respective boxes without tipping or rocking when pressure is brought to bear upon them.
 - 3. Each adjustable valve box cover will have distinctly cast the word "WATER", as indicated on the enclosed drawings. The letters shall be cast on the outside and shall be not less than 3/16 inch in relief.
- D. Fixed Risers must fit the valve box described herewith and shall be the circular or square drop type capable of 1", 1½", 2", 2½" and 3" height increases as specified on the Bid-Schedule of Items Pages. All fixed risers shall accept standard 5¼" drop lids. All risers shall adhere to the same quality standards as the adjustable valve box and covers.
- E. The iron adjustable valve box castings shall be thoroughly cleaned on the outside, and inside surfaces, and be protected from rain or moisture until they are painted.
- F. After the iron adjustable valve box castings have been thoroughly cleaned and inspected and found free from rust, the same shall be coated, painted with or dipped in an asphalt or bituminous base paint or coating. If castings are painted, they will be covered with two coats, the first coat being allowed to dry thoroughly before the second is applied. If castings are dipped, they shall be preheated, and the coating material will be heated to a temperature employed in the coating of cast iron pipe.
- G. The iron adjustable valve box castings shall be weighed after the application of the coal tar varnish and its weight distinctly marked on the castings in white paint. Castings must comply with the minimum weights of valve box parts and valve boxes complete as noted on enclosed drawings.

**SPECIFICATIONS/DESCRIPTIONS OF PRODUCTS AND/OR SERVICES
CITY OF CLEVELAND - DIVISION OF WATER
SECTION C – SUPPLEMENTAL GENERAL CONDITIONS**

ADJUSTABLE VALVE BOXES & APPURTENANCES

C-7 BID REQUEST FOR SAMPLES

- A. Upon the request of the Director of Public Utilities or his designee, bidders may be required to furnish a sample of the item(s) bid.
- B. Samples to be delivered to the Central Warehouse, 4600 Harvard Avenue, Newburgh Heights, Ohio 44105. The samples, of the successful bidder, will be paid for and retained as a standard for the material, design and workmanship of items under these specifications. Samples submitted by unsuccessful bidders may be picked up at the Central Warehouse after passage of the Board of Control Resolution awarding the contract.
- C. Each bidder shall state on the Bid-Schedule of Items pages the locations of the factory, or foundries where the materials to be ordered under these specifications will be made.
- D. Prices bid for Adjustable Valve Boxes & Appurtenances shall include all expenses incurred for patterns.

C-8 ADJUSTABLE VALVE BOX APPROVAL

- A. Some adjustable valve boxes have already been determined by CWD to meet its standards and requirements specs as listed. These are included on the following Approved Materials List.

Company/Manufacturer	Product Name (Valve Box)
Tyler Union	Cast Iron Valve Box, Two Piece , Screw Type
Bingham & Taylor	Valve Boxes, Screw & Slip Type
EJ USA	Valve Boxes, Screw & Slip Type, 2-Piece
Star Pipe Products	Line Valve Box - Long Style Valve Box Round Top and Cover Part No. VBCL; VBLIDLV

Company/Manufacturer	Product Name (Valve Box Lid plain)
Tyler Union	UPC 145325
EJ USA	6800007
Bingham & Taylor	GRE5WHLSK435

**SPECIFICATIONS/DESCRIPTIONS OF PRODUCTS AND/OR SERVICES
CITY OF CLEVELAND - DIVISION OF WATER
SECTION C – SUPPLEMENTAL GENERAL CONDITIONS**

ADJUSTABLE VALVE BOXES & APPURTENANCES

Company/Manufacturer	Product Name (Valve Box Lid tri-skirt)
EJ USA	86252A
Bingham & Taylor	GRE5LHVTSK4WCL35
Star Pipe Products	VBLIDL

- B. Bidders proposing to submit adjustable valve boxes from this pre-approved list need only list the manufacturer proposed on the Bid-Schedule of Items.

Bidders proposing to submit products that are not on CWD’s pre-approved list must submit with its bid, sufficient evidence that the proposed items meet all of CWD’s requirements. Such evidence shall include drawings that fully and distinctly illustrate and describe the proposed adjustable valve box. All dimensions and thickness of metal must be written on the drawings, and the kinds of material to be in each and every part of the construction shall be clearly indicated.

If not provided as part of the bid response, the bidder must provide said evidence within seven calendar days after request/notification to do so. Bidders may also submit three references where the adjustable valve boxes have been used successfully in municipal water systems similar to the City’s.

- C. CWD will evaluate all submitted evidentiary material to determine if the proposed products meet CWD’s standards.
- D. The drawings and specifications submitted and accepted are intended to be explanatory of each other, but should any discrepancy appear or arise as to the importance of anything contained in either, the specifications shall govern. Any correction, error, or omission in the drawings may be made by the Director of DPU when such correction is necessary for the proper fulfillment of the specifications.
- E. After contract award, CWD may require the contractor to modify the drawings as necessary to suit CWD’s needs, this may include submitting the drawings in electronic, vectorized, AutoCAD format.

C-9 EXPERIMENTAL APPARATUS PROHIBITED

When requested by CWD, each bidder shall be required to submit to the Director of DPU, or his designee, proof that each and every part of the product which they propose to furnish is of the form and type that has been advertised for sale and that has been in successful and practical service outside the contractor’s works and has demonstrated the practicability and effectiveness both by test and actual use.

**SPECIFICATIONS/DESCRIPTIONS OF PRODUCTS AND/OR SERVICES
CITY OF CLEVELAND - DIVISION OF WATER
SECTION C – SUPPLEMENTAL GENERAL CONDITIONS**

ADJUSTABLE VALVE BOXES & APPURTENANCES

C-10 METHOD OF AWARD

The award of items will be made to the lowest and best bidder on each separate item shown within the Bid-Schedule of Item pages, unless a combination of items is required to meet specified requirements. If a combination of items is required of the same manufacture, it shall be noted on the Bid-Schedule of Items pages.

C-11 DELIVERY (Supplemental to General Conditions B-14)

Delivery of the items to be purchased under the terms of this bid shall be made after receipt of the order issued by the Commissioner of Purchases and Supplies. Delivery shall be made to the Central Warehouse, 4600 Harvard Avenue, Newburgh Heights, Ohio 44105 between 8:00 A.M. and 3:00 P.M. on any day except Saturdays, Sundays, or City Holidays. Items shall be delivered on pallets, and delivery shall mean that the vendor's truck shall deliver the material to the above location and that CWD shall assist and/or provide personnel to unload the truck. The price bid shall include all costs of delivery. CWD requires a minimum of 24 hours' notice in advance of all deliveries. To provide notice in advance of delivery, contact 216-348-7277 ext. 73600.

C-12 INSPECTION

- A. The Director of DPU, or his designee, shall have the right to inspect the material and work done as the interest of the City may require. Such representative shall have unrestricted access to the contractor's plants and to all parts of the work and other locations at which preparation of the material and the construction of the different parts of the work are performed to fulfill these specifications. He/she shall receive access to all facilities and assistance to carry out his/her work, inspection and testing in a manner satisfactory to the Director of DPU or his designee.
- B. Such inspection shall not relieve the contractor from any obligation to perform said work strictly in accordance with good work practice to produce a product in compliance with these specifications. Products not so furnished shall be removed and made good by the contractor at his own expense, free of all expense to the City, whenever so ordered by the Director of DPU or his designee, without any reference to any previous oversight, acceptance, or error in inspection.
- C. The inspection of all materials to be purchased under the terms of this bid will be made by the City, DPU, CWD, or the duly authorized representative, without cost to the contractor.

**SPECIFICATIONS/DESCRIPTIONS OF PRODUCTS AND/OR SERVICES
CITY OF CLEVELAND - DIVISION OF WATER
SECTION C – SUPPLEMENTAL GENERAL CONDITIONS**

ADJUSTABLE VALVE BOXES & APPURTENANCES

C-13 NOTICE TO PROCEED

The term of this contract shall begin when CWD issues a Notice to Proceed to the vendor(s) and shall last for up to one year. At the City's discretion, the City may shorten the term of this contract to as much as two weeks less than one full year, in order to accomplish an orderly inventory of material. A Notice to Proceed shall not be issued until the contract has been fully executed and delivered to all parties.

C-14 MATHEMATICAL ERRORS

- A. If a bidder makes any mathematical errors in the bid sheets such that some or all of the bid numbers are mathematically inconsistent with each other, the City shall correct such errors as follows. The lowest level values or unit prices shall be deemed as indicating the bidder's true intent and shall be accepted as correct. All further calculations shall then be corrected, and these corrected values shall be cascaded throughout the entire set of bid sheets, potentially affecting the bidder's final bid price. Calculations subject to such correction include, but are not limited to:
1. The summing of labor and material unit prices into a total unit price
 2. The multiplication of unit price times quantity to arrive at the extension cost
 3. The summing of individual line items into totals or subtotals
 4. The multiplication of any subtotals or other values by contingency percentages or other factors
 5. The transferring of subtotals or values from one sheet to another
- B. If the correction of any errors has an effect on the award of the contract, only the directly affected bidders will be notified in writing of the corrections and their affects.

C-15 INVOICING and PAYMENT (Supplemental to General Conditions B-21)

A. INVOICING

The vendor shall submit invoices that appropriately reflect the work performed. Invoices must be typed and legible. Each invoice must be mailed as specified below:

1. Original invoice to the Division of Water, ATTN: Payables Unit, 1201 Lakeside Avenue, 4th Floor South, Cleveland, OH 44114 or payables_unit@clevelandwater.com. The failure to deliver copies of invoices to the indicated location may lead to delays in payment.

**SPECIFICATIONS/DESCRIPTIONS OF PRODUCTS AND/OR SERVICES
CITY OF CLEVELAND - DIVISION OF WATER
SECTION C – SUPPLEMENTAL GENERAL CONDITIONS**

ADJUSTABLE VALVE BOXES & APPURTENANCES

2. A detailed itemization of materials or services provided, including:
 - Date that CWD gave the work assignment to the contractor
 - CWD Release/Work Order Number for each individual release

B. PAYMENT

The bidder must adhere to the terms set forth above under C-11 Delivery and C-15 A. Invoicing sections. CWD will review invoices upon receiving them. In order to perform this review, CWD requires all of the following documentation:

1. Relevant sections (e.g., the Bid - Schedule of Items section) of the contract with the vendor;
2. A City Delivery Order (DO) that authorized the specific services/materials being invoiced;
3. Delivery documentation (e.g., Proof of Service/Delivery slip, Packing Slip, etc.) with an acknowledgement signature and date from a CWD employee;
4. An accurate invoice.

CWD shall pay the vendor for all material purchased under this contract at the vendor's specified price, minus discount quoted. It should also, be noted that CWD will not assume or pay for material handling, cartage fees or taxes. Bidder assumes this liability solely. No separate delivery charges shall be considered or paid, except for emergency situations only.

Each invoice shall include all of the following: manufacturer and part number, exact itemized cost of each part, date of order, date of shipment, listed price, description of item, quantity, applicable discount and extension, to include CWD's actual cost.

The bidder must provide firm documentation of manufacturer's list price for item(s) being purchased at the time of transaction or with invoice. Bidder will submit a photocopy of manufacturer's specific price page(s) and identify where the item(s) appear. The bidder will apply their quoted discount to arrive at CWD's actual cost. All invoices must include both manufacturers' list price and CWD's cost after discount is applied. The vendor is advised that invoices will not be paid unless they are submitted as specified.

The vendor is responsible for providing the delivery documentation at the time of delivery and for submitting the invoice. The CWD will provide the contract and DO copies. A CWD employee will use the above four (4) documents to perform crosschecks to ensure accuracy in invoicing. If all is in order (e.g. delivered/ invoiced items were authorized under the contract and DO, invoiced quantities were delivered, contract prices were invoiced, discounts applied, etc.). CWD will approve payment of the invoice through the City's internal processes. The City's Division of

**SPECIFICATIONS/DESCRIPTIONS OF PRODUCTS AND/OR SERVICES
CITY OF CLEVELAND - DIVISION OF WATER
SECTION C – SUPPLEMENTAL GENERAL CONDITIONS**

ADJUSTABLE VALVE BOXES & APPURTENANCES

Accounts subsequently handles processing of the payment request, and the Division of Treasury issues the payment.

C-16 OEO PARTICIPATION GOALS (Supplemental to A-17, A-18, and B-23)

Under Chapter 187.13C of the Codified Ordinances, the OEO participation goal for this requirement contract has been waived. Schedules 1-4 are not required.

There is no Subcontractor Participation (Utilization) Goal for this contract. However, per Section A-19(a) of the Instructions to Bidders, any and all proposed subcontractors, whether City certified or not, must be divulged and listed in the sealed bid. If you do plan to utilize a subcontractor, submit a proposed subcontractor list on a separate, signed sheet of paper, listing the name, address, type of work or materials, and total subcontractor amount for each and every subcontractor that you propose to use on this contract.

You are encouraged to consider City-certified firms for any available subcontracting opportunities. A searchable database of all City-certified firms can be found on the City of Cleveland Office of Equal Opportunity Website:

<http://cleveland.diversity compliance.com>

On the website, click on CSB/MBE/FBE Registry.

**SPECIFICATIONS/DESCRIPTIONS OF PRODUCTS AND/OR SERVICES
CITY OF CLEVELAND - DIVISION OF WATER
SECTION C – SUPPLEMENTAL GENERAL CONDITIONS**

ADJUSTABLE VALVE BOXES & APPURTENANCES

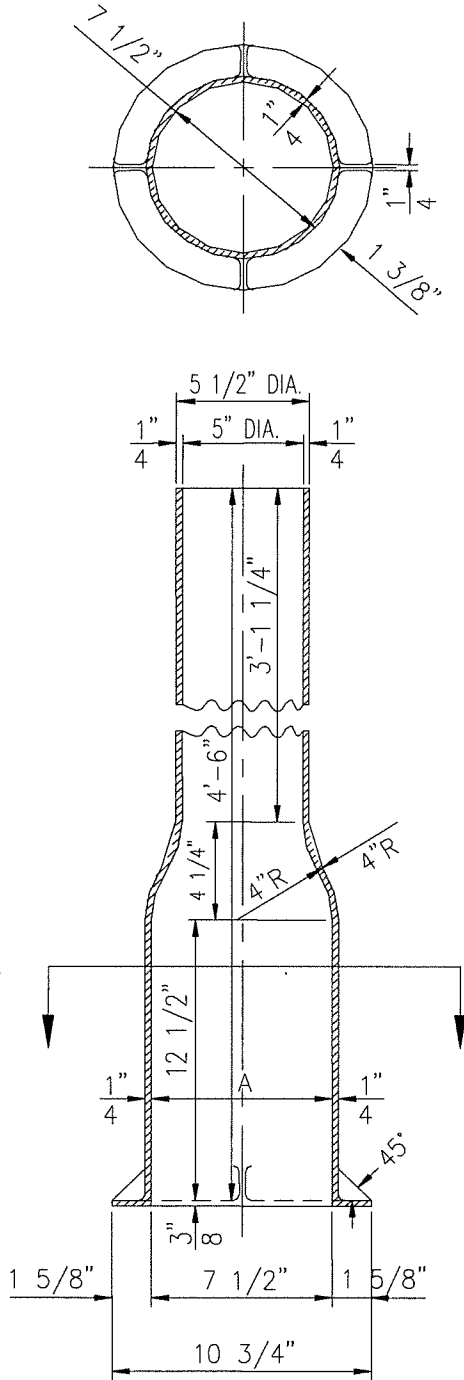

BASE NO. 2 & 3
EST. WT. 71 POUNDS

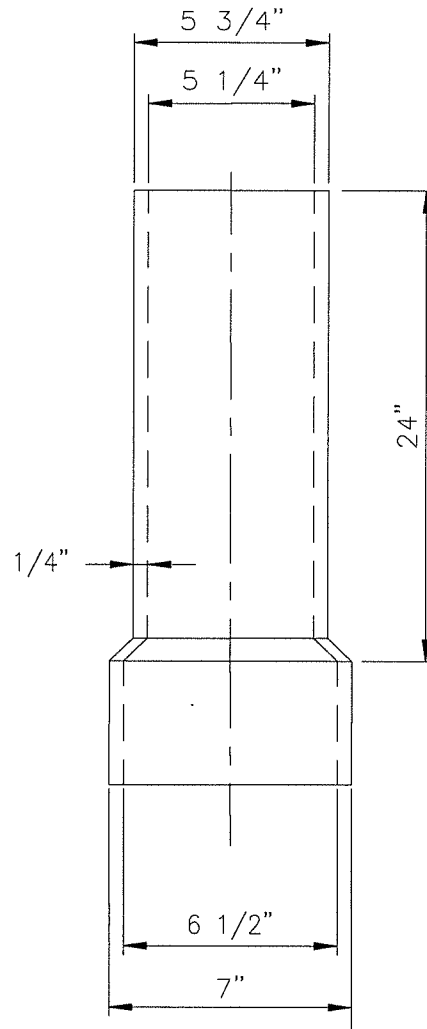

EXTENSION
WT 35-38 POUNDS

SK-1236-A-1

**SPECIFICATIONS/DESCRIPTIONS OF PRODUCTS AND/OR SERVICES
CITY OF CLEVELAND - DIVISION OF WATER
SECTION C – SUPPLEMENTAL GENERAL CONDITIONS**

ADJUSTABLE VALVE BOXES & APPURTENANCES

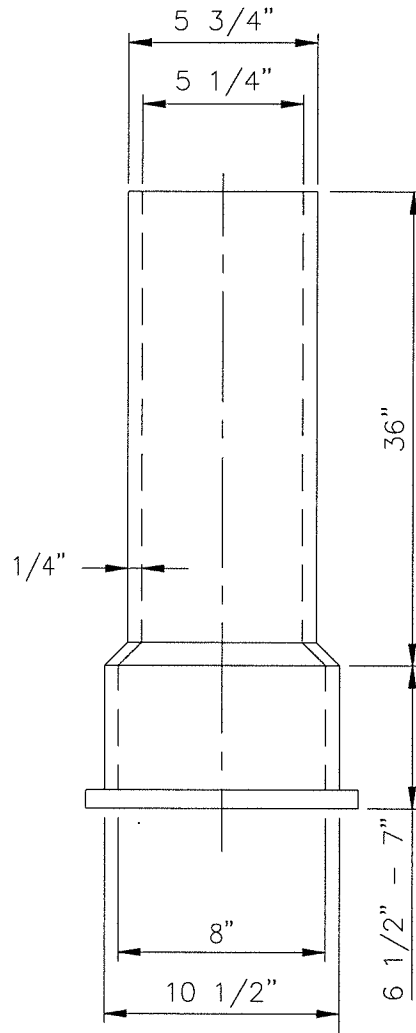

ALTERNATE BOTTOM No. 1
WT 44-45 POUNDS

SK-1236-A-2

**SPECIFICATIONS/DESCRIPTIONS OF PRODUCTS AND/OR SERVICES
CITY OF CLEVELAND - DIVISION OF WATER
SECTION C – SUPPLEMENTAL GENERAL CONDITIONS**

ADJUSTABLE VALVE BOXES & APPURTENANCES

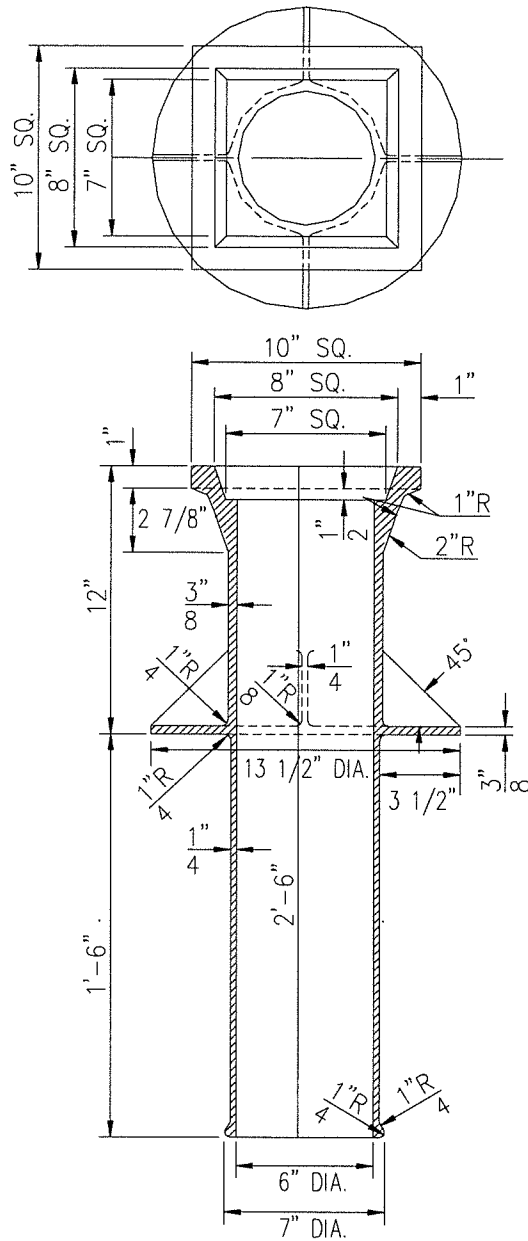

TOP NO. 3 & 4 (SQUARE COVER)
EST. WT. 73 POUNDS

SK-1236-B-1

**SPECIFICATIONS/DESCRIPTIONS OF PRODUCTS AND/OR SERVICES
CITY OF CLEVELAND - DIVISION OF WATER
SECTION C – SUPPLEMENTAL GENERAL CONDITIONS**

ADJUSTABLE VALVE BOXES & APPURTENANCES

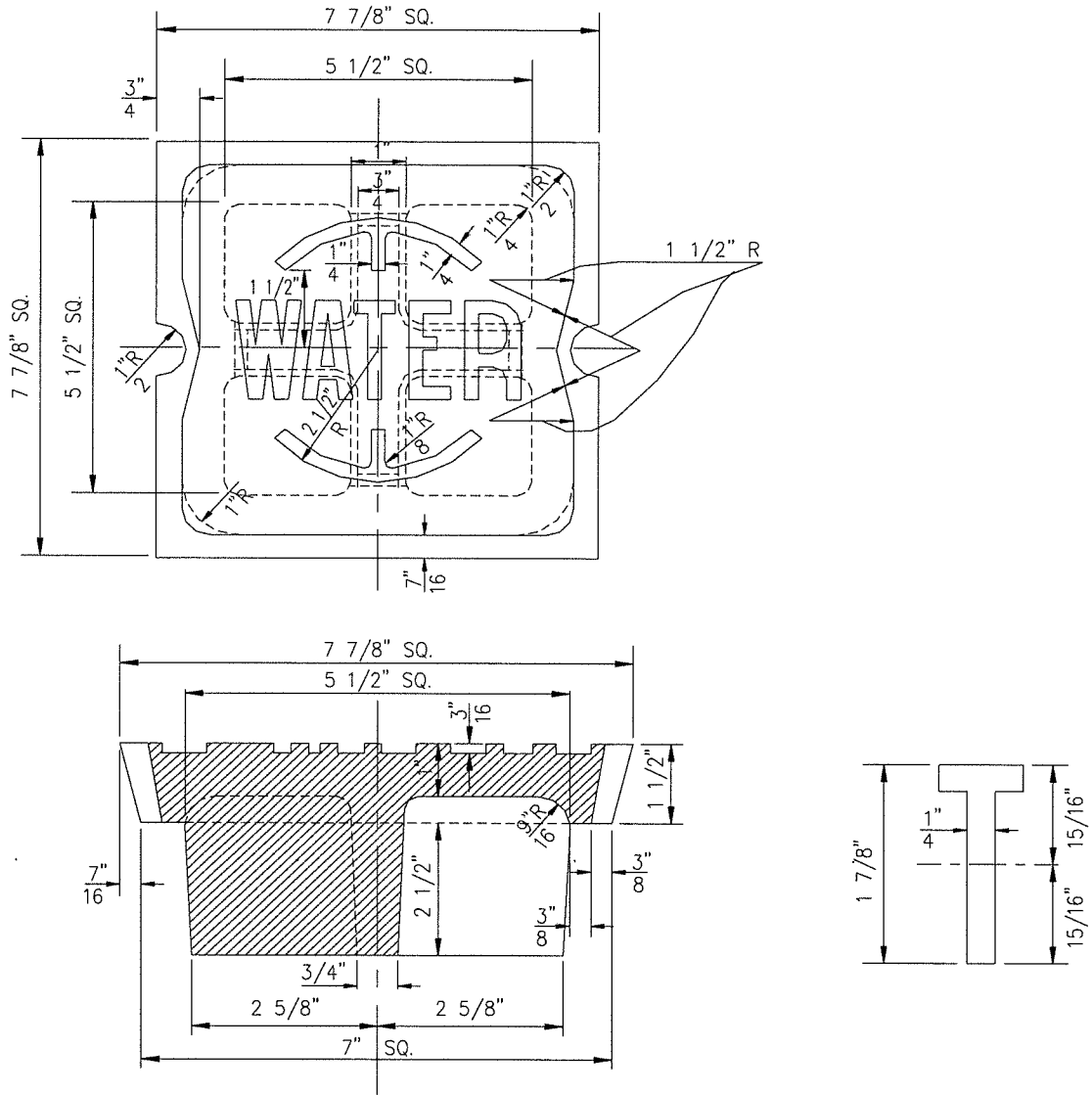

SQUARE COVER FOR No. 3 & 4 TOP

WT. 23 LBS.

SK-1236-B-2

**SPECIFICATIONS/DESCRIPTIONS OF PRODUCTS AND/OR SERVICES
CITY OF CLEVELAND - DIVISION OF WATER
SECTION C – SUPPLEMENTAL GENERAL CONDITIONS**

ADJUSTABLE VALVE BOXES & APPURTENANCES

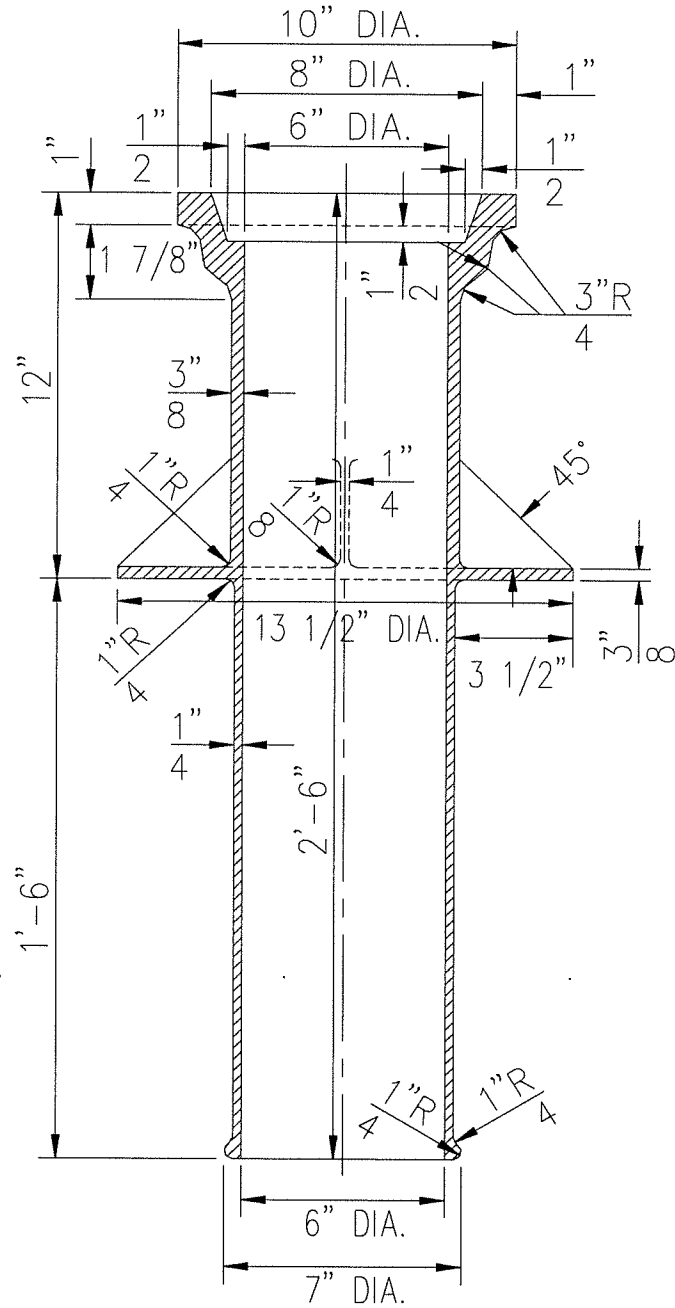

TOP NO. 1 & 2 (ROUND HEAD)

EST. WT. 73 POUNDS

SK-1236-B-3

**SPECIFICATIONS/DESCRIPTIONS OF PRODUCTS AND/OR SERVICES
CITY OF CLEVELAND - DIVISION OF WATER
SECTION C – SUPPLEMENTAL GENERAL CONDITIONS**

ADJUSTABLE VALVE BOXES & APPURTENANCES

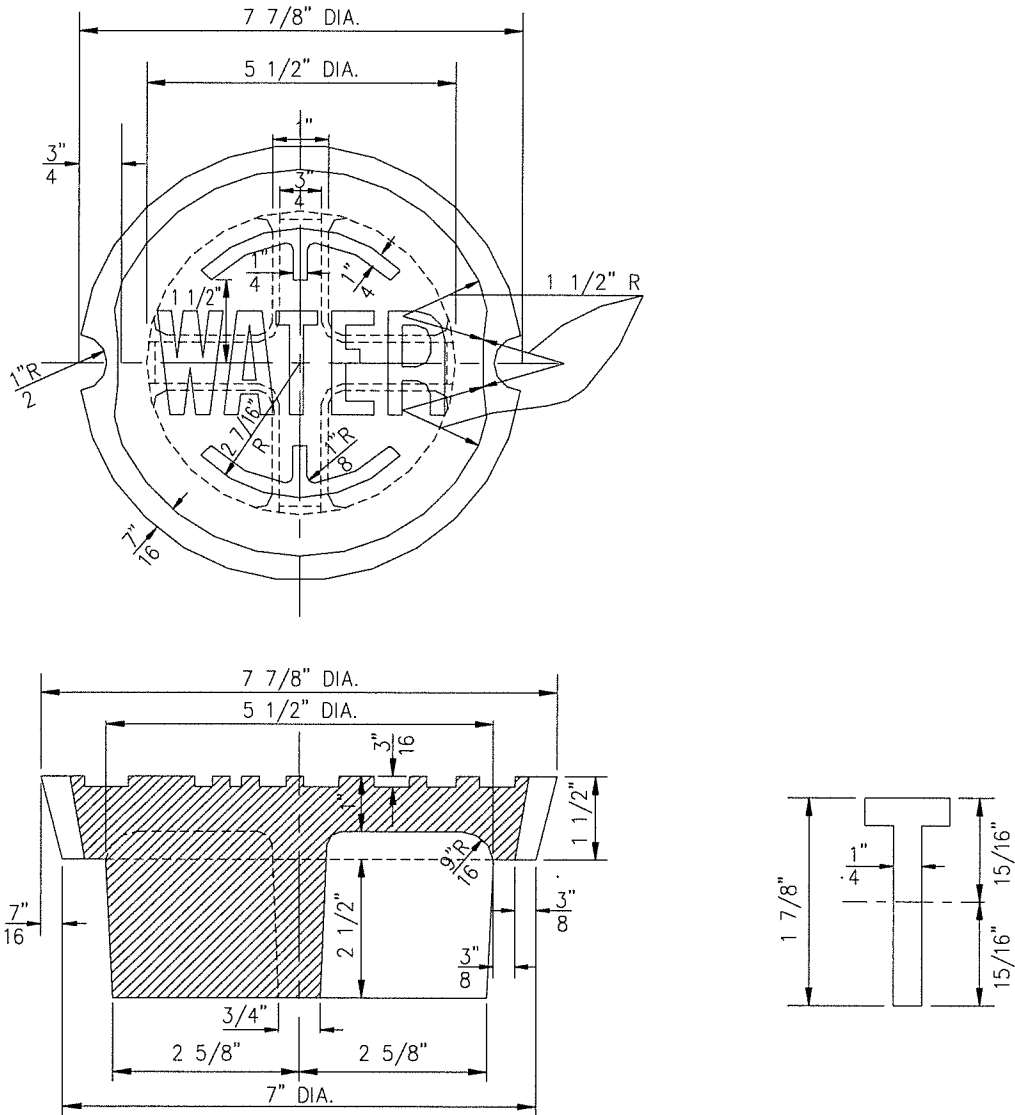

ROUND COVER FOR No. 2 TOP

WT. 20 LBS.

SK-1236-B-4

**SPECIFICATIONS/DESCRIPTIONS OF PRODUCTS AND/OR SERVICES
CITY OF CLEVELAND - DIVISION OF WATER
SECTION C – SUPPLEMENTAL GENERAL CONDITIONS**

ADJUSTABLE VALVE BOXES & APPURTENANCES

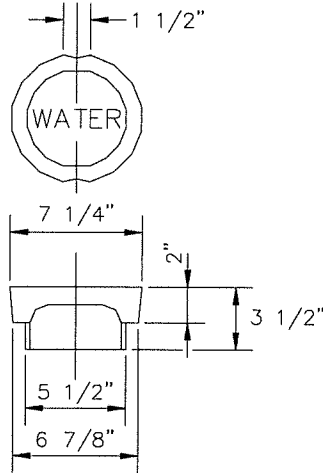

ALTERNATE COVER NO. 1

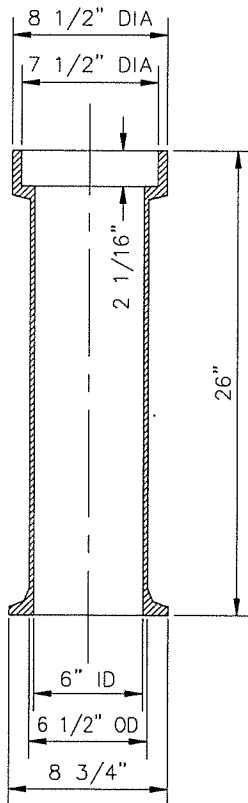

ALTERNATE LONG TOP NO. 1
WEIGHT 55.5 POUNDS

SK-1236-B-5

**SPECIFICATIONS/DESCRIPTIONS OF PRODUCTS AND/OR SERVICES
CITY OF CLEVELAND - DIVISION OF WATER
SECTION C – SUPPLEMENTAL GENERAL CONDITIONS**

ADJUSTABLE VALVE BOXES & APPURTENANCES

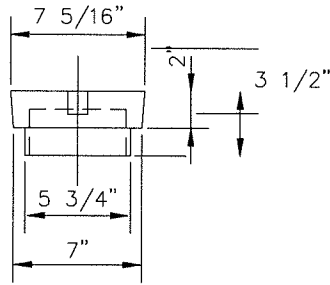

ALTERNATE COVER NO. 2
WEIGHT 13 POUNDS

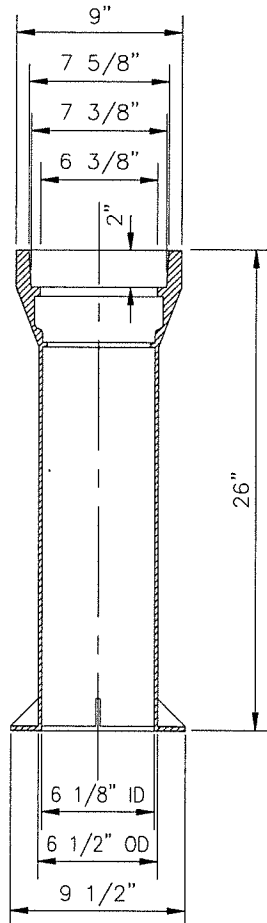

ALTERNATE LONG TOP NO. 2
WEIGHT 65 POUNDS

SK-1236-B-6

**SPECIFICATIONS/DESCRIPTIONS OF PRODUCTS AND/OR SERVICES
CITY OF CLEVELAND - DIVISION OF WATER
SECTION C – SUPPLEMENTAL GENERAL CONDITIONS**

ADJUSTABLE VALVE BOXES & APPURTENANCES

"New Style"

5 1/4" VALVE BOX RISER

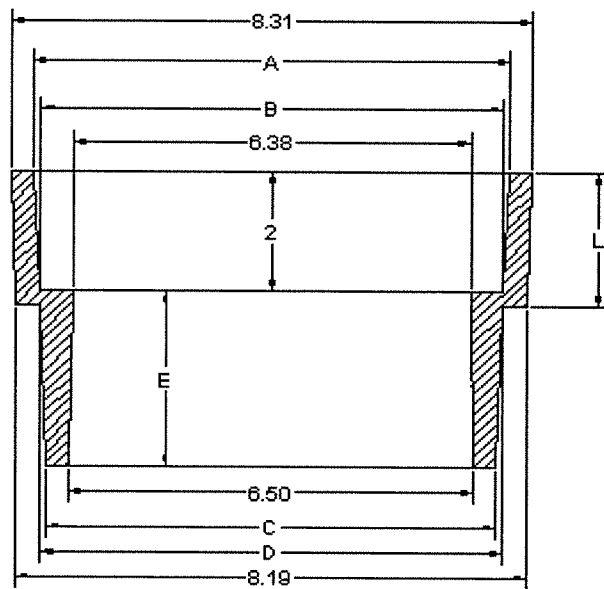

E	L	A	B	C	D
1	0.88	7.44	7.09	7.19	7.5
1.5	1.38	7.44	7.09	7.19	7.5
2	1.25	7.44	7.09	7.19	7.5
2.5	2.25	7.63	7.38	7.19	7.38
3	2.25	7.63	7.38	7.19	7.38

**SPECIFICATIONS/DESCRIPTIONS OF PRODUCTS AND/OR SERVICES
CITY OF CLEVELAND - DIVISION OF WATER
SECTION C – SUPPLEMENTAL GENERAL CONDITIONS**

ADJUSTABLE VALVE BOXES & APPURTENANCES

"Old Style"

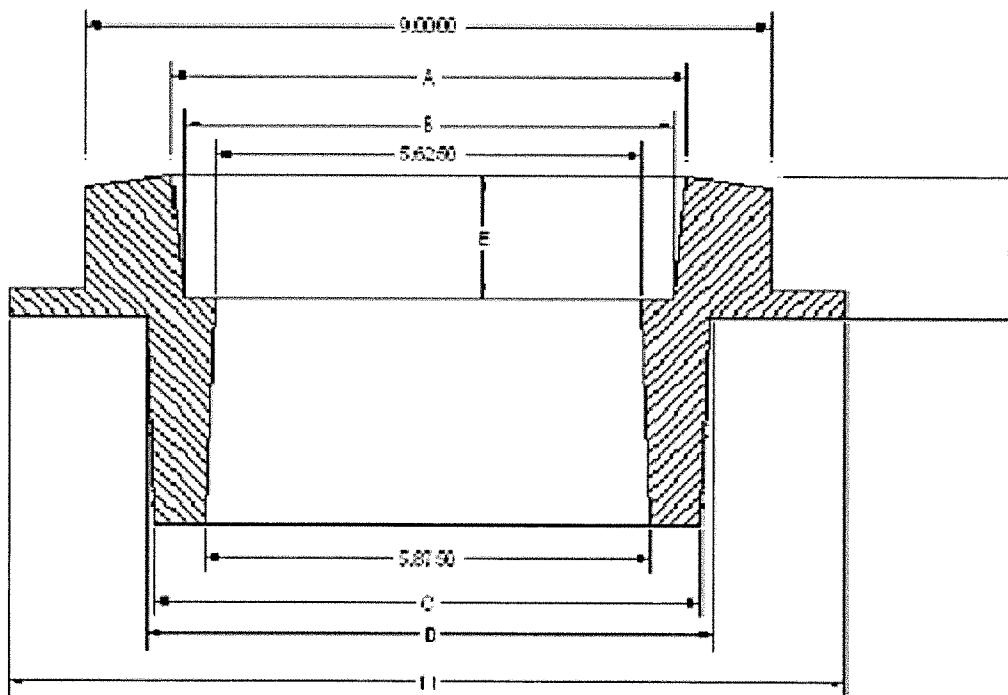

such that
the fixed

Although no drawings of square and oval risers have been included, such risers shall meet the following requirements.

Risers shall fit into the corresponding approved valve box. Square risers must fit the box shown in drawing SK-1236-B-1. Oval risers must fit SK-1236-B-5. There should be no more than 3/16th of an inch of clearance between the sides of the riser and the valve box. The risers shall accommodate corresponding square or oval approved lids.

**SUPPLEMENTAL
NOTICE TO BIDDERS**

NORTHERN IRELAND FAIR EMPLOYMENT PRACTICES DISCLOSURE

INSTRUCTIONS: Under Sec. 181.36 Cleveland Codified Ordinances, the information requested on this page must be supplied by all Contractors and any Subcontractors having more than a fifty percent (50%) interest in the proposed contract before the City will award a contract. Any Contractor or Subcontractor that is found to have made a false statement in the Disclosure shall be in default of its bid and/or contract obligations and shall be subject to the remedies for default contained in its contract. For failure to cure such a default, a Contractor or Subcontractor shall be automatically ineligible to bid to supply any goods or services to the City for a period of two years.

CHECK WHICHEVER IS APPLICABLE:

A. () The undersigned or any controlling shareholder, *subsidiary, or parent corporation of the undersigned is NOT ENGAGED IN ANY BUSINESS OR TRADING FOR PROFIT IN NORTHERN IRELAND. (If paragraph A. is checked, proceed to the signature line.)

B. () The undersigned or any controlling shareholder, *subsidiary, or parent corporation IS ENGAGED IN ANY BUSINESS OR TRADING FOR PROFIT IN NORTHERN IRELAND. (If paragraph B. is checked, please either check the stipulation contained in paragraph C. or attach documentation that shows that the undersigned has complied with the stipulation contained in paragraph C.)

C. () The undersigned and all enterprises identified in paragraph B. are TAKING LAWFUL AND GOOD FAITH STEPS TO ENGAGE IN FAIR EMPLOYMENT PRACTICES WHICH ARE RELEVANT TO THE STANDARDS EMBODIED IN THE "MacBRIDE PRINCIPALS FOR FAIR EMPLOYMENT IN NORTHERN IRELAND." A copy of the MacBride Principles can be obtained from the Office of the Commissioner of Purchases and Supplies. In lieu of checking this paragraph, the undersigned must attach documentation which the undersigned believes shows compliance with the stipulation contained in this paragraph C.

Name of Contractor or Subcontractor

By: _____

Title: _____

*"Controlling shareholder" means any shareholder owning more than fifty percent (50%) of the stock in the corporation or more than twenty-five percent (25%) of the stock in the corporation if no other shareholder owns a larger share of stock in the corporation.

**SUPPLEMENTAL
NOTICE TO BIDDERS**

**Subject: Submission of NORTHERN IRELAND FAIR EMPLOYMENT PRACTICES
DISCLOSURE**

Each bidder and/or appropriate parties should complete the DISCLOSURE and submit it with the bid, if possible. If not submitted with the bid, it must be completed and submitted to the Commissioner of Purchases and Supplies before the City will award a contract. If a bidder or appropriate parties fail to complete and submit it, they shall not be eligible for a contract award.

EQUAL OPPORTUNITY CLAUSE
(Section 187.22(b) C.O.)

Each Contract also shall contain the following equal opportunity clause:

*During the performance of this contract, the contractor agrees as follows:

- (1) The contractor shall not discriminate against any employee or applicant for employment because of race, religion, color, sex, sexual orientation, national origin, age, disability, ethnic group or Vietnam-era or disabled veteran status. The contractor shall take affirmative action to insure that applicants are employed and that employees are treated during employment without regard to race, religion, color, sex, sexual orientation, national origin, age, disability, ethnic group, or Vietnam-era or disabled veteran status. As used in this chapter, "treated" means and includes without limitation the following: recruited, whether by advertising or other means; compensated, whether in the form of rates of pay or other forms of compensation; selected for training, including apprenticeship, promoted, upgraded, demoted, downgraded, transferred, laid off and terminated. The contractor agrees to and shall post in conspicuous places, available to employees and applicants for employment, notices to be provided by the hiring representatives of the contractor setting forth the provisions of this nondiscrimination clause.
- (2) The contractor will, in all solicitations or advertisements for employees placed by or on behalf of the contractor, state that the contractor is an equal opportunity employer.
- (3) The contractor shall send to each labor union or representative of workers with which he has a collective bargaining agreement or other contract, or understanding, a notice advising the labor union or worker's representative of the contractor's commitments under the equal opportunity clause, and shall post copies of the notice in conspicuous places available to employees and applicants for employment.
- (4) It is the policy of the City that local businesses, minority-owned businesses and female-owned businesses shall have every practicable opportunity to participate in the performance of contracts awarded by the City subject to the applicable provisions of the Cleveland Area Business Code.
- (5) The contractor shall permit access by the Director or his or her designated representative to any relevant and pertinent reports and documents to verify compliance with the Cleveland Area Business Code, and with the Regulations. All such materials provided to the Director or designee by the contractor shall be considered confidential.
- (6) The contractor will not obstruct or hinder the Director or designee in the fulfillment of the duties and responsibilities imposed by the Cleveland Area Business Code.
- (7) The contractor agrees that each subcontract will include this Equal Opportunity Clause, and the contractor will notify each subcontractor, material supplier and supplier that the subcontractor must agree to comply with and be subject to all applicable provisions of the Cleveland Area Business Code. The contractor shall take any appropriate action with respect to any subcontractor as a means of enforcing the provisions of the Code."



MAYOR'S OFFICE OF EQUAL OPPORTUNITY
PARTICIPATION INFORMATION FORM
(Requirement and Standard Contracts)

The Subcontractor Participation Goals for this contract are:

0% CSB Participation

A searchable database of all CSB Subcontractors eligible to fulfill these subcontractor participation goals can be found on the City of Cleveland Office of Equal Opportunity Website:

<http://www.city.cleveland.oh.us/CityofCleveland/Home/Business/Equal%20Opportunity>

Click on [CSB/MBE/FBE Registry](#).



DIVISION OF PURCHASES & SUPPLIES

Subcontractors Notice

There is no Subcontractor Participation (Utilization) Goal for this contract. However, per Section A-19 or 22(a) of the Instructions to Bidders, any and all proposed subcontractors, whether City certified or not, must be divulged and listed in the sealed bid. If you do plan to utilize a subcontractor, submit a proposed subcontractor list on a separate, signed sheet of paper, listing the name, address, type of work or materials, and total subcontractor amount for each and every subcontractor that you propose to use on this contract.

You are encouraged to consider City-certified firms for any available subcontracting opportunities. A searchable database of all City-certified firms can be found on the City of Cleveland Office of Equal Opportunity Website:

<http://www.city.cleveland.oh.us/oeo>

On the website, click on CSB/MBE/FBE Registry.